

SixTRAK® Combination I/O Modules

Double density I/O expansion for SIXNET controllers and RTUs

Select this SixTRAK® module when . . .

. . . you have a mix of I/O types, and reduced panel space and lowest cost are important requirements.

- Up to 16 Discrete Inputs, 8 Discrete Outputs, 8 Analog Inputs and 4 Analog outputs in one compact module
- High density design saves space and reduces cost
- 16 bit A/D converter for precision measurements
- DIN rail or direct panel mountable
- True hot swap of modules in live systems
- Ideal for small RTU or remote station applications

This module combined with a VersaTRAK IPm makes the perfect small RTU system.

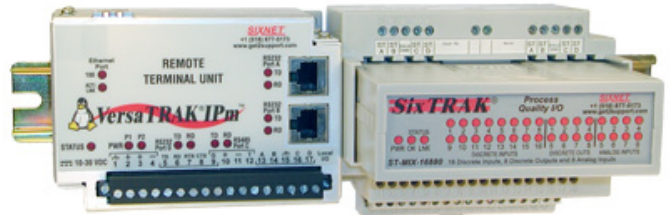

The VersaTRAK IPm is the ultimate open Remote Terminal Unit with open-source Linux software, powerful communications and advanced programming capabilities.

(Note: The ST-MIX is supported only by IPm-based SIXNET Controllers, RTUs, and Gateways.)



ST-MIX16880-D

This model has 16 discrete inputs, 8 discrete outputs, and 8 analog inputs.

ST-MIX12884-D

This model has 12 discrete inputs, 8 discrete outputs, 8 analog inputs and 4 analog outputs.

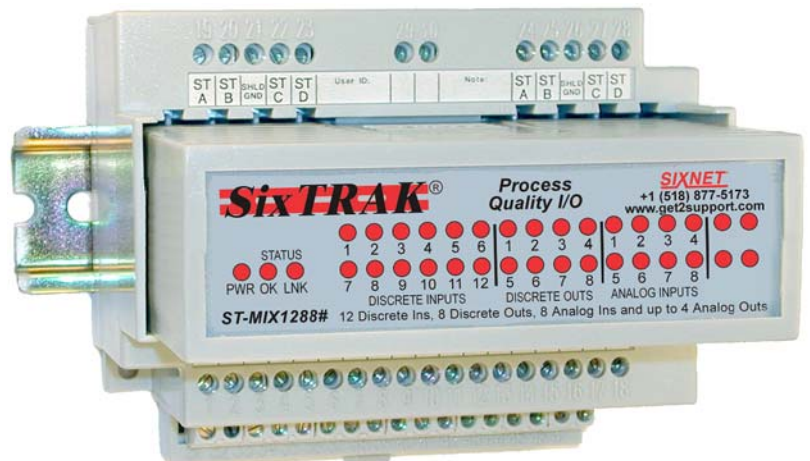

Performance Specifications

Discrete inputs	12 or 16 channels
Voltage range	10-30 VDC (sinking or sourcing)
Guaranteed ON voltage	9 VDC
Maximum voltage	30 VDC
Guaranteed OFF volt & current	5.0 VDC & 1.5 mA DC
Input resistance	10K Ohms
Input current @ 24 VDC	3 mA
Filtered ON/OFF delay	25 mS (20 Hz max. counting)
Fast ON/OFF delay	4 mS (100 Hz max. counting)
Counter Inputs	1st 8 Discrete Channels
Maximum count rate	100 Hz. (10 KHz. on channel 1)
Counter modes	Pulse, rate and run-time
Pulse-rate mode period	0.1 second to 1 minute
Run-time mode options	Seconds or minutes
Discrete Outputs	8 channels
Voltage range	10-30 VDC (sourcing only)
Max. output per channel	1 Amp
Max. output per module	8 Amps
Max. OFF state leakage	0.05 mA
Minimum load	1 mA
Inrush current (100 mS surge)	5 Amps
Typical ON resistance	0.3 Ohms
Typical ON voltage (@ 1A)	0.3 VDC
Analog Inputs	8 channels
Range	4-20 mA
A/D resolution	16 bits (0.003%)
Full scale accuracy	+/-0.1% (@20°C)
Span & offset temp. coefficient	+/-50 ppm per degree C
Input impedance	100 Ohm
Current protection	Self-resetting fuses
Open loop detection	Yes, reports negative below 4 mA
DMRR (differ. mode rejection)	66 dB at 50/60 Hz
Analog Outputs	up to 4 channels
Range	4-20 mA
D/A resolution	16 bits (less than 1µA)
Full scale accuracy	+/- 0.02% (@20°C)
Span & offset temp coefficient	+/- 50 ppm per °C typical
Max output settling time	5 mS (to .05%)
Load resistance range	0-750 Ohms (@ +24 VDC)
Short Circuit protection	Current limiting
Environmental	DIN rail or panel mounting
Input voltage	10-30 VDC
Maximum ST-Bus power	1500 mW (10-30 VDC)
Isolation (I/O to ST-Bus)	1200 Volts
Operating temp. range	-40 to +70°C (-40 to +85°C storage)
Humidity (non-condensing)	5 to 95% RH
Vibration	IEC68-2-6
Electrical safety	 UL508, CSA C22.2/14;EN61010 FCC part 15, ICES-003, EN55022 EN50082-1,EN61326-1
EMI emissions	
EMC immunity	
Surge withstand	IEEE-472
Hazardous locations (Class 1, Div 2 and Zone 2)	UL1604, CSA C22.2/213, EN50021, EEx nA II T4 X
Marine/offshore locations	Det Norske Veritas (DNV)

Specifications are subject to change. Consult the factory for latest information.

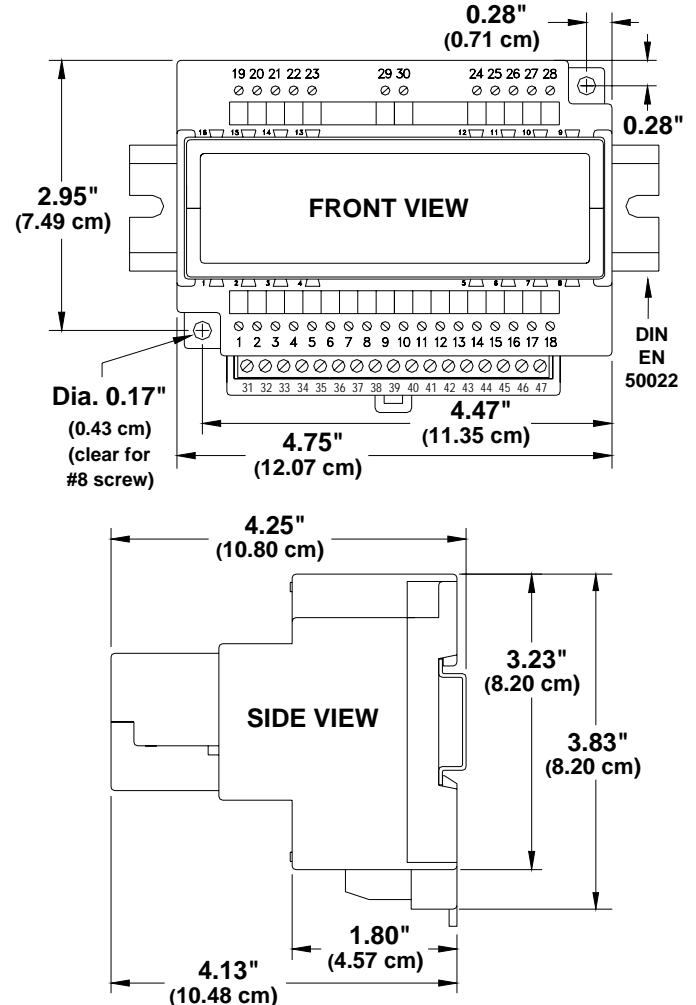

Ordering Information

ST-MIX16880-D	16 DI, 8 DO, 8 AI
ST-MIX12884-D	12 DI, 8 DO, 8 AI, 4 A0
ST-MIX####-M	Replacement module only
ST-MIX####-DB	Replacement base only

The ST-MIX combination I/O modules are part of the SixTRAK I/O product line. Up to 20 of these modules (any mix) can be connected to the high-speed I/O bus of SIXNET controllers, RTUs and I/O gateways.

(Note: The ST-MIX is supported only by IPm-based SIXNET Controllers, RTUs, and I/O Gateways. Consult SIXNET for details.)

Advanced I/O Features and Capabilities

Discrete I/O Features

There are several groups of discrete I/O in these combination I/O modules that offer different capabilities to accommodate a variety of system needs. Refer to the notes below and the wiring diagrams (next page) for further details.

→ **Sinking or Sourcing Discrete Inputs** (First four on ST-MIX12884 or all sixteen on the ST-MIX16880)

This group of inputs may be configured as sourcing inputs (ON when positive voltage is applied) or sinking inputs (switch closures to ground). There is a selection jumper in the module's base that is easily accessed by unplugging the logic module and opening the hinged door. You must also make a similar selection in the Discrete Options window in the I/O tool Kit software. The module performs a check to verify that the hardware and software selections match.

→ **Adjustable Threshold Voltage** (First four discrete inputs on ST-MIX12884 only)

This group of inputs may be modified to transition at a threshold voltage lower than the factory setting. This is accomplished by simply soldering an extra resistor into the base. Refer to the user manual for details.

→ **Sourcing Discrete Inputs** (Second group of eight discrete inputs on the ST-MIX12884 only)

This group of eight discrete inputs on the ST-MIX12884 is sourcing only with the standard 10 – 30 volt range.

→ **Sourcing Discrete Outputs and Watchdog Output** (both models)

The eight outputs are sourcing (positive voltage applied when ON) with the standard 10-30V range. The first discrete output can be configured to be a watchdog output. This system performance monitor will be ON if the output module is functioning normally, the gateway is functioning normally or the ST-Bus communications are occurring normally

→ **High Speed and Special Counter Inputs** (both models)

The first eight discrete inputs can be configured as counters with a flexible choice of modes. These counters report their values in corresponding 16-bit analog input registers. Options for fast (5 mS) or slow (25 mS for contact bounce filtering) response providing a maximum count rate of 100 Hz or 20 Hz counting, respectively. The 1st channel is a high speed counter and can count up to 20 KHz. Available counter modes are pulse, rate and run-time.

Analog I/O Features

→ **Self-resetting Analog Input Protection**

Each 4-20 mA input channel has a 100 ohm, high precision (0.1 percent) shunt across its input to develop a 2 volt signal when a full scale 20 mA input is applied. These shunts are located in the module's base, giving you the advantage of maintaining a continuous circuit even if the logic module is removed from the base. If excessive voltage is applied to an input, a self-resetting fuse will open to help prevent the shunt from overheating.

→ **Open Loop Detection on Analog Inputs**

This module can detect and report an open instrumentation loop on its analog inputs. By allowing the module to report a negative value if the current falls below 4 mA, low limit logic in your DCS, PLC, RTU or computer can signal the loss of current. To enable this feature, select the "Go Negative Below 4 mA" software setting for each channel.

→ **Reading Voltage Analog Inputs**

As an option, a voltage divider may be factory populated to replace the 20 mA (100 ohm) shunt of one or more input channels. These alterations are made in the wiring base, so they may be tailored for particular installations. (The logic modules are not altered so they remain interchangeable!) Voltage operation may be configured in the I/O Tool Kit by selecting the appropriate range for the corresponding input. Consult SIXNET for ordering instructions.

→ **LED Indicators for Analog Inputs**

There is a LED for each of the analog input channels. The LED will be ON when the channel is within the normal operating range of 4-20 mA. The LED will be OFF when an open loop is detected.

ST-MIX####-D Power, ST-BUS and I/O Wiring

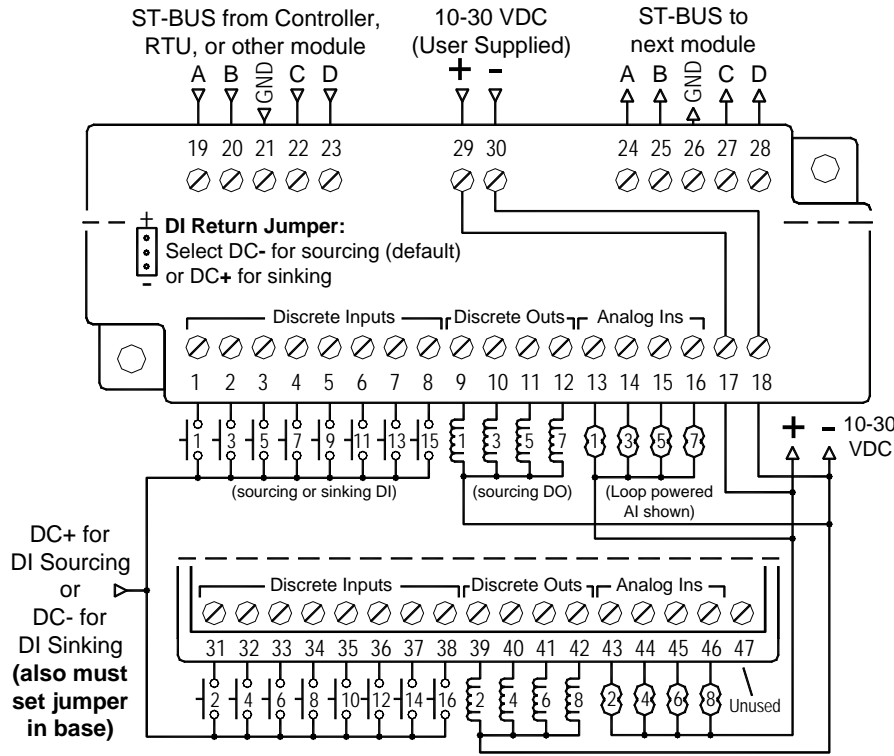

ST-MIX-16880-D

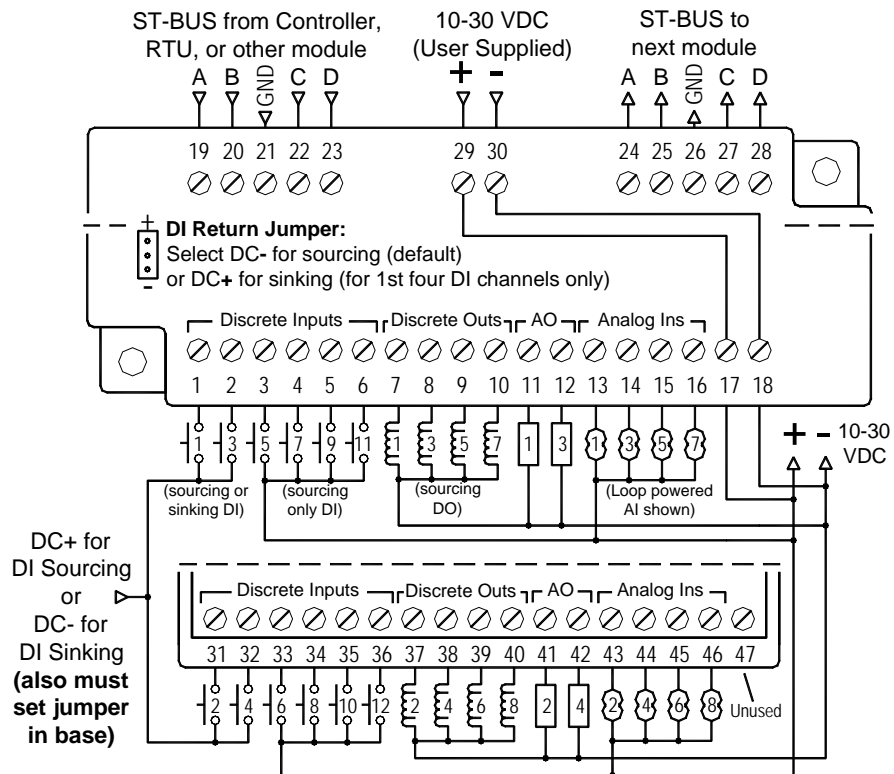

ST-MIX-12884-D

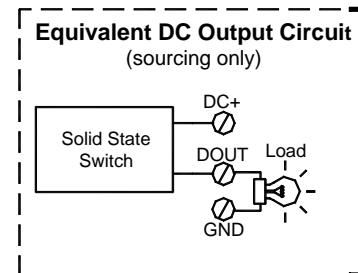
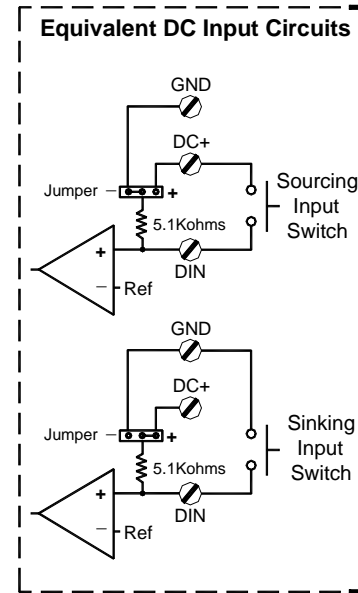
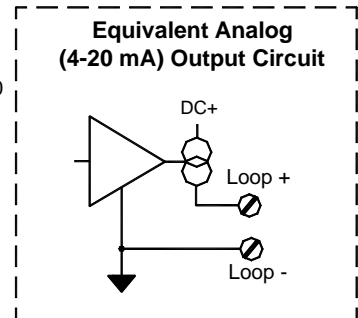
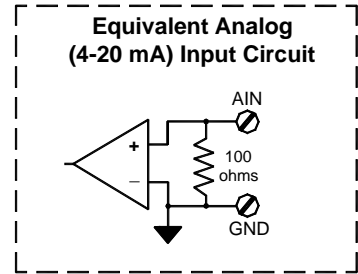

Revised 26-Oct-04