

SixTRAK IPm Controller *VersaTRAK IPm RTU*

Installation and Maintenance

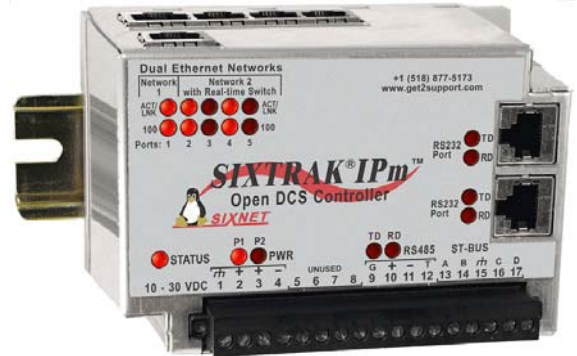

Contents at a Glance:

Section 1	Overview	3
Section 2	Assembly and Installation	7
Section 3	Power and ST-Bus Wiring	9
Section 4	Controller or RTUs	13
Section 5	Technical Specifications	16
Section 6	Maintenance Information	19
Section 7	Service Information	20

This manual applies to the following SIXNET products:
ST-IPM-####, VT-IPM-####

PROTECTED TECHNOLOGY POLICY

SIXNET protects your investment in SIXNET systems with long-term planned technology and our unique Protected Technology Policy. We will continue to support the specified capabilities of standard SIXNET products for at least five years. We plan each product improvement and new feature to be upward compatible with existing designs and installations. Our goals are to make each new software release bring new power to your SIXNET systems and have every existing feature, applications program and data file continue to work.

We protect your investment even further with a liberal five-year trade-in policy. Exchange standard products for upgraded versions of the same product to take advantage of new features and performance improvements at any time for five years. A prorated trade-in allowance will be given for your existing equipment.

SIXNET protects your long-term productivity with state-of-the-art planned technology and continued support.

STATEMENT OF LIMITED WARRANTY

SIXNET, manufacturer of SixTRAK, VersaTRAK, RemoteTRAK and EtherTRAK products, warrants to Buyer that products manufactured by SIXNET will be free from defects in material and workmanship. SIXNET's obligation under this warranty will be limited to repairing or replacing, at SIXNET's option, the defective parts within 1 year of the date of installation, or within 18 months of the date of shipment from the point of manufacture, whichever is sooner. Products may be returned by Buyer only after permission has been obtained from SIXNET. Buyer will prepay all freight charges to return any products to the repair facility designated by SIXNET.

This limited warranty does not cover losses or damages that occur in shipment to or from Buyer or due to improper installation, maintenance, misuse, neglect or any cause other than ordinary commercial or industrial applications. This limited warranty is in lieu of all other warranties whether oral or written, expressed or implied. SIXNET's liability shall not exceed the price of the individual unit which is the basis of the claim. In no event shall SIXNET be liable for any loss of profits, loss of use of facilities or equipment or other indirect, incidental or consequential damages.

INSTALLATION AND HAZARDOUS AREA WARNINGS

These products should not be used to replace proper safety interlocking. No software-based device (or any other solid-state device) should ever be designed to be responsible for the maintenance of consequential equipment or personnel safety. In particular, SIXNET disclaims any responsibility for damages, either direct or consequential, that result from the use of this equipment in any application.

All power, input and output (I/O) wiring must be in accordance with Class I, Division 2 wiring methods and in accordance with the authority having jurisdiction.

WARNING – EXPLOSION HAZARD – SUBSTITUTION OF COMPONENTS MAY IMPAIR SUITABILITY FOR CLASS 1, DIVISION 2.

WARNING – EXPLOSION HAZARD – WHEN IN HAZARDOUS LOCATIONS, DISCONNECT POWER BEFORE REPLACING OR WIRING MODULES.

WARNING – EXPLOSION HAZARD – DO NOT DISCONNECT EQUIPMENT UNLESS POWER HAS BEEN SWITCHED OFF OR THE AREA IS KNOWN TO BE NONHAZARDOUS.

<p>Note: All information in this document applies to SixTRAK IPm Open Controller, SixTRAK I/O Controller, and VersaTRAK IPm RTU, except where otherwise noted. Refer to the SIXNET I/O Tool Kit software online help system for detailed product specifications and configuration settings.</p>
--

Section 1

Overview

Introduction

The products covered by this manually are designed for use in industrial control and data acquisition systems. Refer to the SIXNET Electronic catalog and the individual data sheets for complete features and benefits. This user manual covers the aspects of hardware installation and maintenance. For software features and capabilities please refer to SIXNET's Electronic help System accessible from within the SIXNET I/O Tool Kit software.

A typical SIXNET station consists of an AC to DC power supply; a SIXNET controller or RTU, controller, or RTU; and modular I/O modules. The I/O modules can be interfaced via Ethernet (EtherTRAK), RS485 (RemoteTRAK), or the ST-BUS (SixTRAK). Just about any combination of these components along with third party hardware and software can be used to make a system.

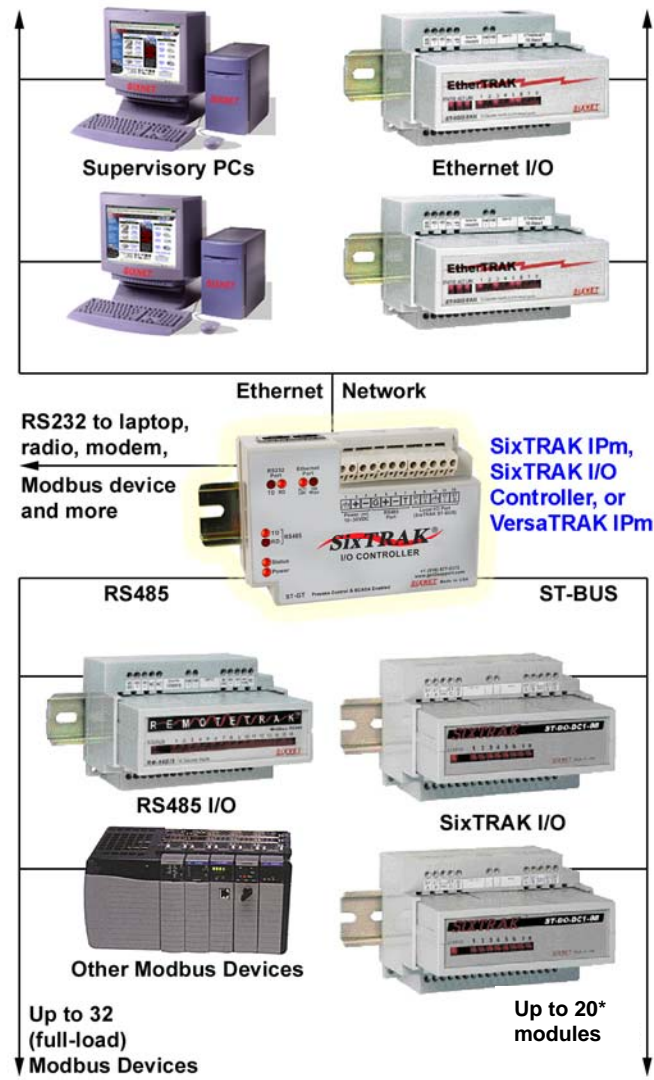

*more with an ET-GT-ST-# I/O concentrator

These SIXNET products offer practically unlimited I/O expansion and communication connectivity.



**SixTRAK IPm Open Controller
ST-IPM-####**



**VersaTRAK IPm RTU
VT-IPM-####**

SIXNET Products Covered by this Manual

**SIXNET
Software Tools**



**SIXNET
I/O Tool
Kit**

SIXNET supplies the "mission oriented" tools you need for every step of your project from the initial specification, through startup, and years of trouble free operation. Configuration information flows between SIXNET Windows, saving you time (you don't have to enter data multiple times) and dramatically reducing data entry errors. Refer to the on-line help in the SIXNET I/O Tool Kit for complete details.

The SIXNET I/O Tool Kit is a configuration, calibration and maintenance tool for SIXNET hardware. Use the I/O Tool Kit to configure I/O features, perform channel-by-channel calibrations in meaningful engineering units, and perform live diagnostics at each station. Refer to the electronic help for details.

Here are the optional Feature Sets for the SIXNET I/O Tool Kit:

SCS (Scalable Control System) features

Includes importing, tag exporting, I/O transfers, advanced load options, and the IOMap shared database. The SCS option is required to develop ISaGRAF programs, using the ISaGRAF Workbench.

Datalogging

Includes Sixlog datalogging including automatic host and client transfers.

Open LINUX features

Gain access to LINUX-visible features in IPm controllers, including file loading and advanced diagnostics. A library of functions to access the IPm I/O registers and other services is supplied with this enhanced license.

Web Server Access

IPm controllers contain an internal web page that reports status information. Obtain a license to load customizations to this web page.



Sixlog

Sixlog is datalogging software for SIXNET controller or RTUs, controllers, and RTUs. Data is logged into protected memory in the unit. Then Sixlog uploads the data files and saves them into ASCII format files that are easy to import into databases, spreadsheets and other Windows applications. Access the Sixlog functions from within the SIXNET I/O Tool Kit.



ISaGRAF

The ISaGRAF Workbench allows you to write an IEC 61131 control program for a SIXNET controller or RTU. All 5 of the IEC 61131 languages are supported, including Ladder Logic and Function Blocks.

Following these steps will make installation and start-up easier.

① Mount the Hardware

If you purchased a TrakPak packaged system, the complete enclosure is ready for installation on any flat surface. If you purchased individual components, refer to the following sections of this or the appropriate user manuals for information on installing them into an enclosure.

② Install ST-BUS or Communication Wiring to I/O Modules

Make ST-BUS wiring connections to any SixTRAK I/O modules. Refer to a following section for ST-BUS wiring guidelines. Make the necessary communication connections to any EtherTRAK or RemoteTRAK I/O modules. If you have a TrakPak packaged system, all these connections have already been done for you.

③ Connect Power and I/O Wiring to the Modules

Connect AC power to the SIXNET or user supplied power supply. Make DC power connections from the power supply to the SIXNET components. Make field wiring connections to the SIXNET I/O modules and any peripheral equipment. Refer to the appropriate user manuals for I/O connection details.

④ Install Communication Cabling

The units covered by this manual come with communication accessories. Snap the pre-wired RJ45 to DB9 adapter to the RJ45 patch cord (not supplied). Connect this cable between one of the serial RS232 ports (RJ45 connector) on your controller or RTU and a serial RS232 port (DB9 connector) on your PC.

Fabricate and install RS232 and RS485 cables as needed to connect to other devices. If you are using Ethernet units, install the correct cabling and peripherals. Refer to the documentation for your Ethernet communication devices for details.

⑤ Apply Power

Power up the SIXNET components and related peripherals. Observe the status LED on each unit. Typically a solid ON indicates proper operation. A blinking LED may indicate that the unit needs to be configured. Refer to the appropriate SIXNET user manual for details.

⑥ Configure Using the SIXNET I/O Tool Kit

Refer to the steps on the next page to create a hardware configuration for each SIXNET station. Refer to the on-line help in the I/O Tool Kit for details.

⑦ Test the Hardware

Use the Test I/O window in the I/O Tool Kit program to verify proper I/O operation of all SIXNET stations. Refer to the I/O Tool Kit on-line help system.

⑧ Configure Your PC Software to Communicate with the SIXNET station(s)

Refer to the documentation for your software.

⑨ If You Have Difficulty

If you experience startup trouble, refer to a following page in this document for some troubleshooting tips or go to www.sixnet.com. If you still need assistance then please contact SIXNET.

Using SIXNET Windows Software



Below is a quick overview of using the SIXNET I/O Tool Kit. It is supplied on the SIXNET CD and registering for Level 1 (basic features) is free.

Note: An expanded version of this page has been provided as on-line help. To access it, click on the Getting Started icon in the I/O Tool Kit online help.

Basic Configuration: Run the SIXNET I/O Tool Kit program and create your panel layouts. Then configure operating parameters for each SIXNET component, including channel tag names. Link the SixTRAK I/O modules (if any) and load your configuration to the controller or RTU. Assign virtual I/O modules and I/O transfers for any EtherTRAK or RemoteTRAK modules you wish to have the controller or RTU poll. Save this information to a project file. Using the Test I/O function, verify that you can read and write all your I/O.

Note: Set tag name restrictions in the SIXNET I/O Tool Kit program before creating tag names to ensure compatibility when exporting them for usage in other Windows applications.

Your SIXNET components are now ready to exchange I/O data with your Windows applications via DDE, OPC, or direct DLL calls. (Refer to the "How to Access SIXNET I/O From a Windows Application" topic in the SIXNET I/O Tool Kit online help.) If you will be running a Windows application, then continue with the following steps.



Exporting I/O Definitions: (optional, requires the SCS feature set) Some Windows applications, such as ISaGRAF, Citect and Intellution FIX, can import SIXNET tag names. If your Windows application supports this feature, run the SIXNET I/O Tool Kit and open your project file. Export your tag names to a file using the appropriate format.

Note: If you are exporting tag names for ISaGRAF, Citect or Intellution, you must create, or already have, a project to export tag data into.



Datalogging: (optional, requires the Datalogging feature set) If you will be logging data in the SIXNET controller or RTU, then create the appropriate datalog configuration(s) and load them into the unit. Refer to the Sixlog topics in the SIXNET I/O Tool Kit online help for details.



IEC 61131 Programming: (optional, requires the SCS feature set) If you are using the ISaGRAF IEC1131 programming software, refer to the SIXNET ISaGRAF on-line help for detailed instructions.



LINUX capabilities: (optional, requires the IPm Advanced feature set) If you are using the advanced LINUX IPm capabilities, refer to the SIXNET I/O Tool Kit on-line help for detailed instructions.

Section 2

Assembly and Installation

SixTRAK Panel Assembly

Most SIXNET components snap onto DIN rail strips fastened to a subpanel. Figure 2-1 shows a sample panel with DIN rail strips and wire duct attached. Recommended DIN rail spacing is 8 inches. This spacing allows room for wire duct to be installed without obstructing field wiring installation.

The SIXNET components are typically installed against one another, but space may be left between modules to accommodate other DIN rail mounted components such as terminal blocks and fuse holders. End clamps are recommended to restrict side-to-side movement. Figure 2-2 shows the physical dimensions of the units covered by this manual.

SIXNET components can be installed in any orientation and order on your panel.

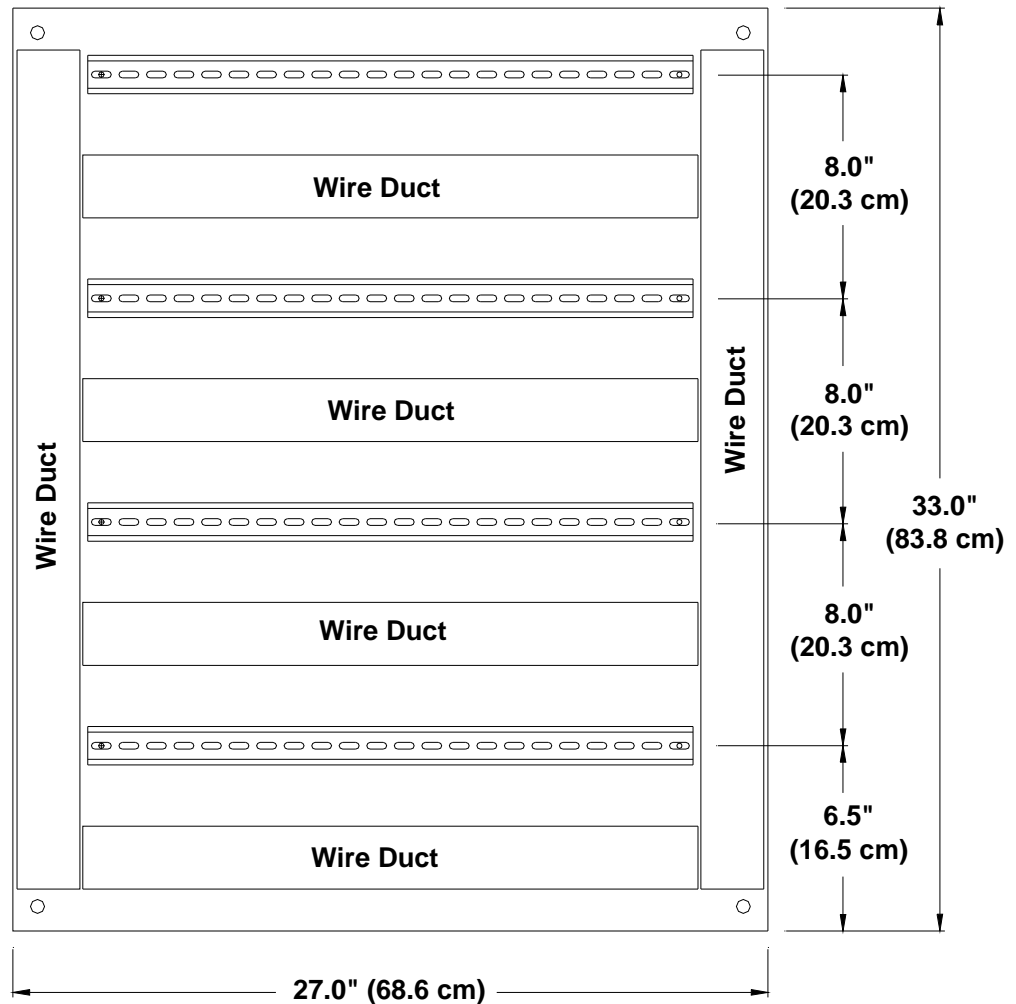

Sample Layout For a 36" x 30" Enclosure
(Figure 2-1)

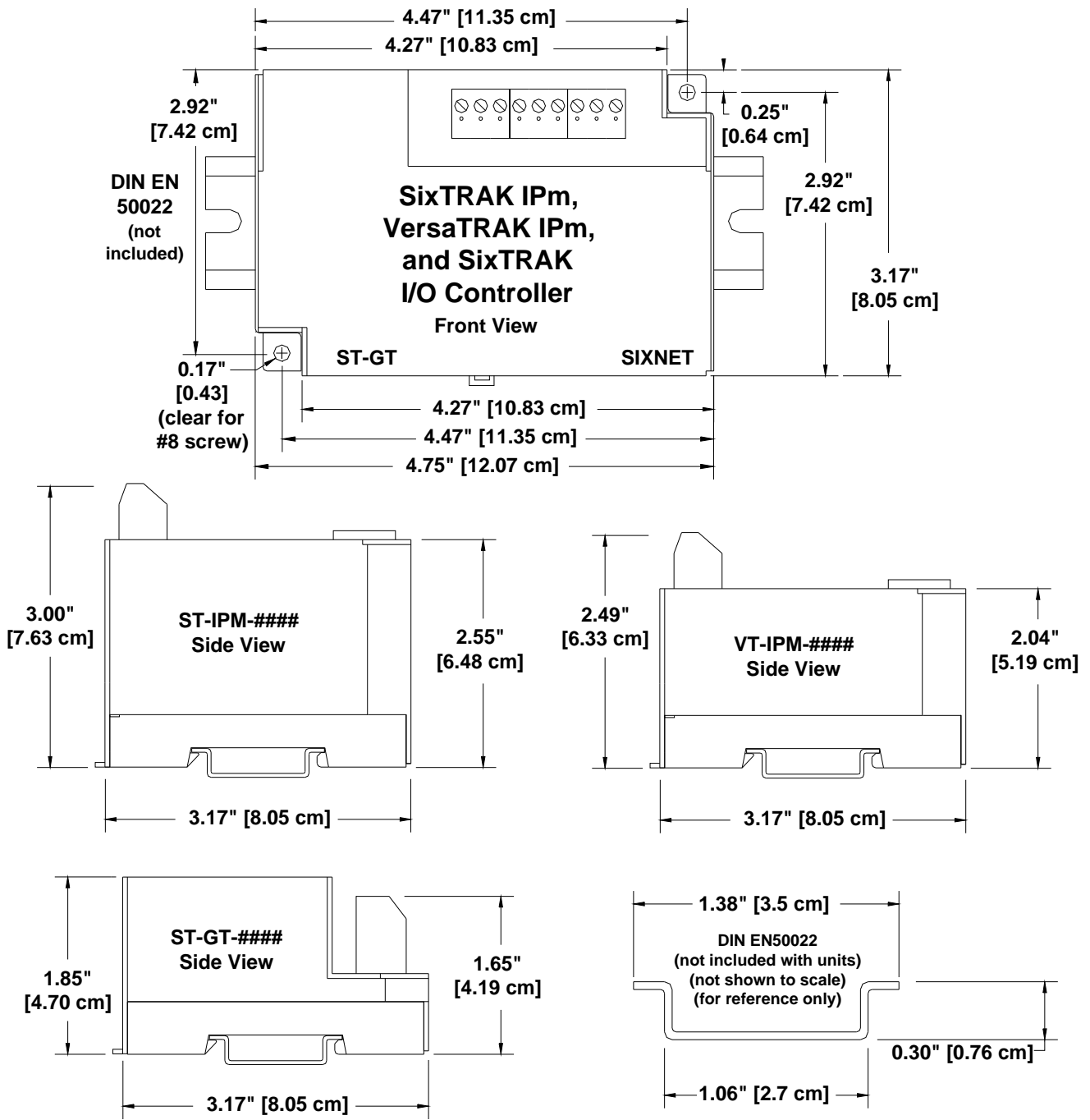

IPm Controllers and RTU Dimensions
(Figure 2-2)

Section 3 Power and ST-Bus Wiring

Power Requirements

ST-PS-024-02N (24VDC @ 2A)

SIXNET IPm controllers and RTU accept 24 VDC power from a SIXNET power supply (ST-PS-024-02N or RM-PS-024-01F) or from a user DC power source of **10 to 30 VDC**.

The SixTRAK power supply operates on 90 to 260VAC (47 to 63 Hz.). Refer to Figure 3-1 for connections. Tighten these screw terminals to a maximum of 3.48 in.-lbs.

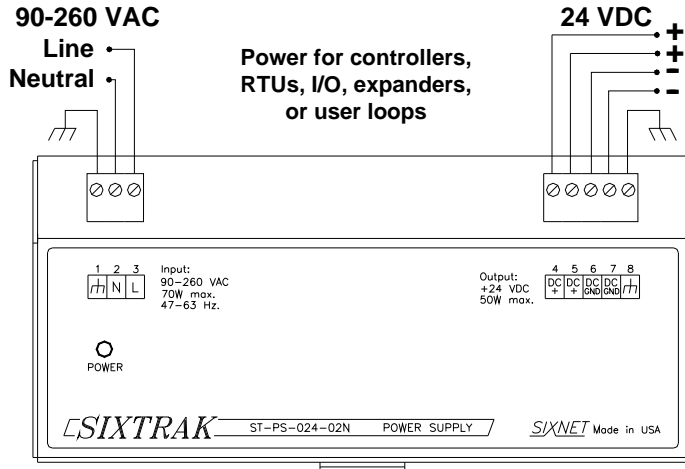

**ST-PS-024-02N
Power Connections**

(Figure 3-1)

RM-PS-024-01F (24VDC @ 1A)

The RM-PS-024-01F operates on 85-264 VAC (47-63 Hz) or 120-370 VDC. Refer to Figure 3-2 for connections. Tighten the screw terminals to a maximum of 3.48 in.-lbs.

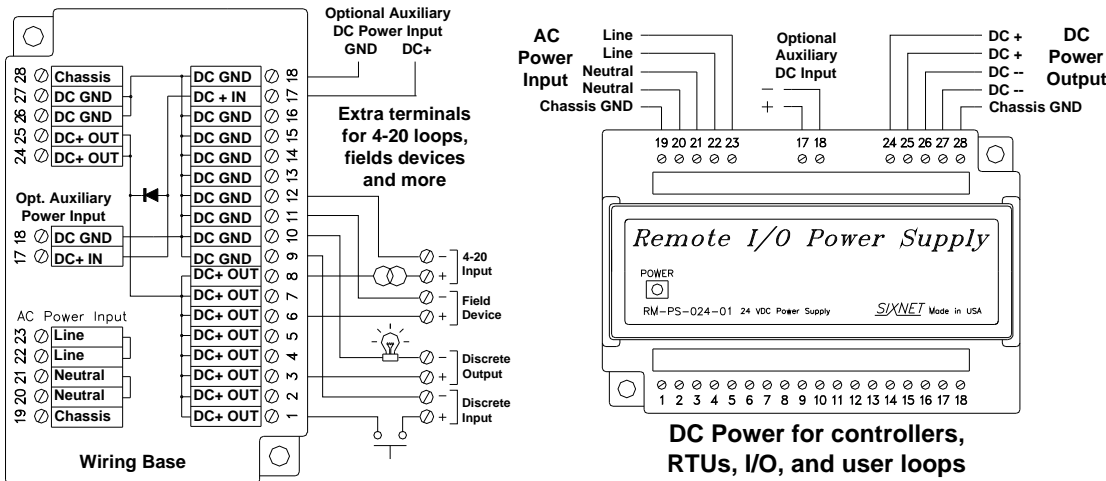

**RM-PS-024-01F
Power Connections**

(Figure 3-2)

RM-PS-024-01F Redundant Power

The RM-PS-024-01F allows you to connect auxiliary 24 VDC power (from another RM-PS-024-01F or other source) to terminals 17 and 18. When auxiliary power is connected, the RM-PS-024-01F will source most of the power, under normal operating conditions. If the primary power fails then the auxiliary power will immediately take over.

Current Requirements

To calculate the current requirements, add the wattage required for the SIXNET controller or RTU, and modules in use. Then divide the total wattage by the DC power source voltage. Then add any current needed for user instrumentation loops.

DC Power Wiring

All SIXNET units and user instrumentation loops may be powered from a single DC source. Refer to Figure 3-3 and 3-4 for typical DC power connections. The user DC power source must be between **10 to 30 volts**.

Redundant Power Inputs

The SixTRAK IPm and VersaTRAK IPm have redundant power + input terminals. (There is one common power – terminal.) This allows you to connect two separate power supplies. If one fails then the other will take over powering your hardware. The SixTRAK I/O Controller can also have redundant power inputs but requires an externally wired diode. See figure 3-4.

Note: In the SixTRAK IPm and VersaTRAK IPm, the ST C (+) and ST D (-) of the SixTRAK ST-BUS are internally connected to only the primary power input (terminals 2 and 4). Therefore, when running on only auxiliary power (terminals 3 and 4) then there will be no power on terminals 16 and 17 (ST C and ST D). If redundant power is desired for the ST-BUS it is recommended that the auxiliary power + be connected to terminal 16 through an external diode. The diode should be appropriately sized (current rating) for the number of SixTRAK I/O modules being powered. See figure 3-3.

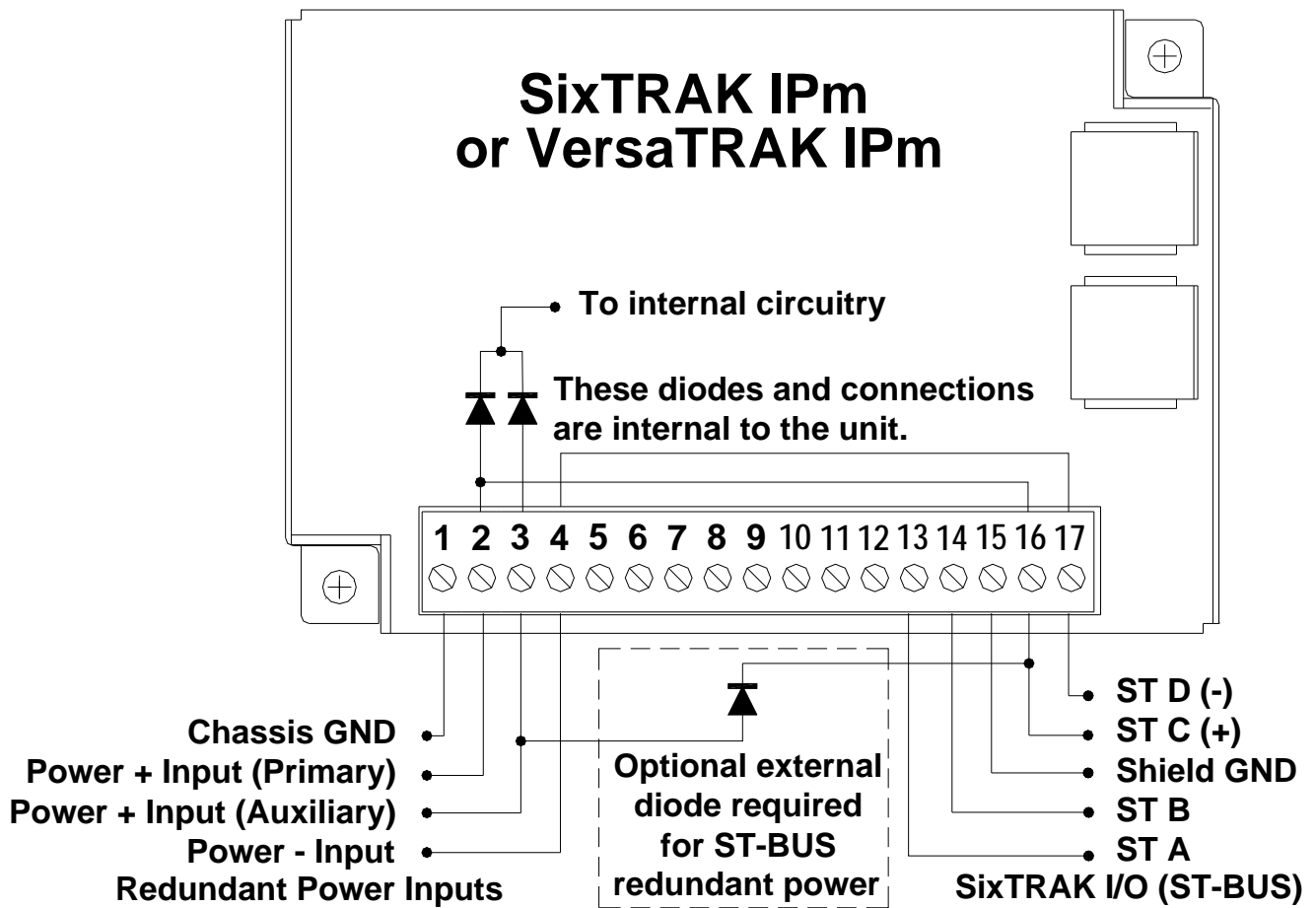

SixTRAK IPm and VersaTRAK IPm Power Connections
(Figure 3-3)

ST-Bus Wiring Guidelines

ST-Bus Capability

ST-Bus wiring connects the SixTRAK I/O modules and expanders to the controller or RTU. Follow the upcoming guidelines for reliable performance.

Max. modules controlled by one controller or RTU	128
Max. modules or expanders connected directly to controller or RTU	20 (any mix)
Max. modules connected to expander output	20 (any mix)
Required cable type	Any with 2 individually shielded pairs, 22AWG min.
Recommended cables	Alpha 2466C, Belden 8723, Carol C1352
Max. cabling off each controller, RTU or expander	50 ft. (16M)

ST-EX-001-20U I/O Expander

See the SixTRAK I/O User manual for details on using the ST-EX-001-20U I/O expander.

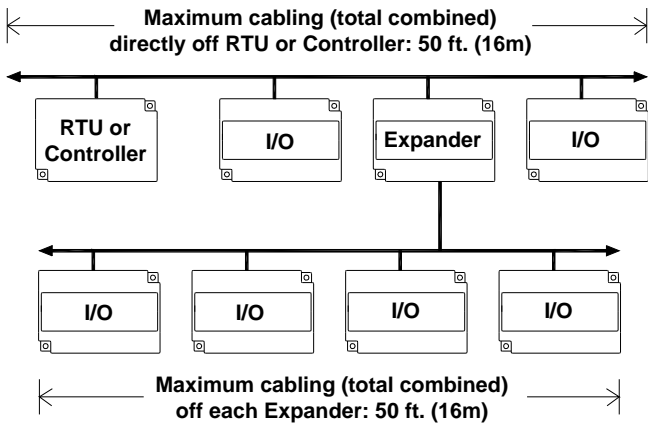

Connect up to 20 I/O modules or expanders directly to the controller or RTU with a maximum total cabling of 50 feet. Likewise, connect up to 20 I/O modules to each expander.

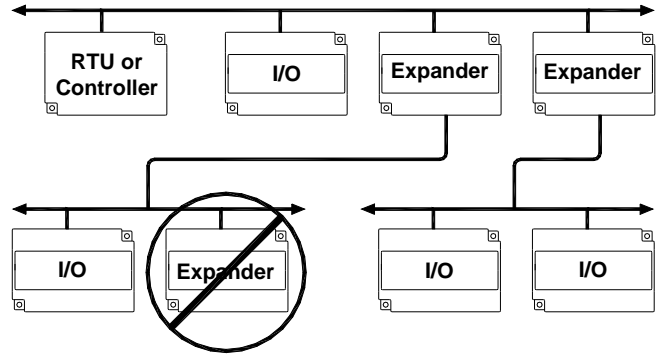

All expanders must be connected directly to the controller or RTU. (Expanders cannot be cascaded in series.)

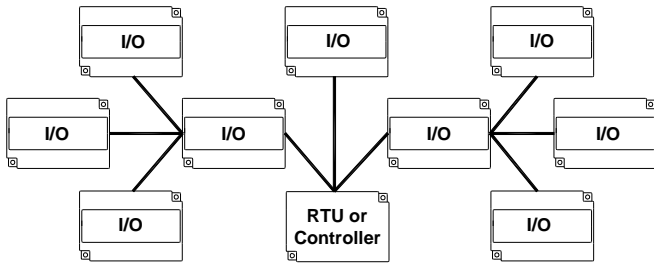

ST-Bus connections may form star configurations without any restrictions.

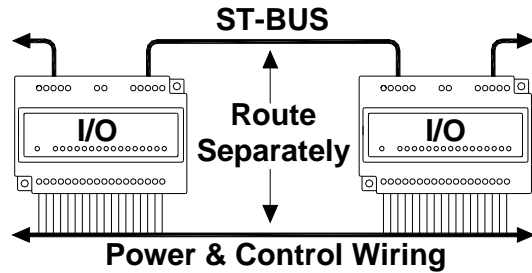

Route ST-Bus wiring away from power wiring and sources of electrical interference.

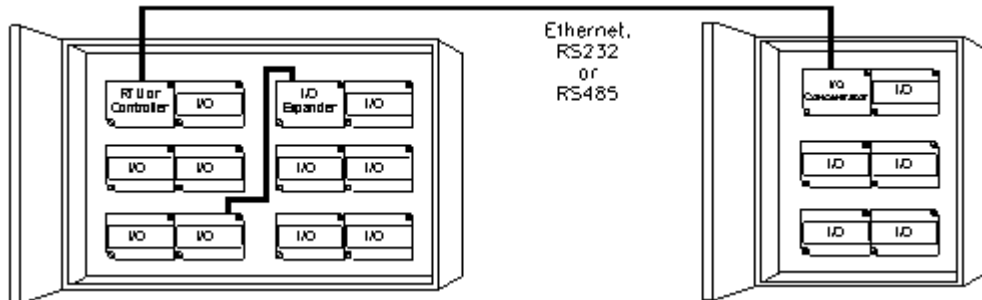

Expanders may be used in cabinets with more than 20 I/O modules as long as the total length of wire stays within the 50-foot limit. Extending ST-Bus wiring to additional cabinets is not recommended. Instead, use a gateway, RTU or I/O concentrator in each additional cabinet and run Ethernet, RS232 or RS485 wiring between the cabinets.

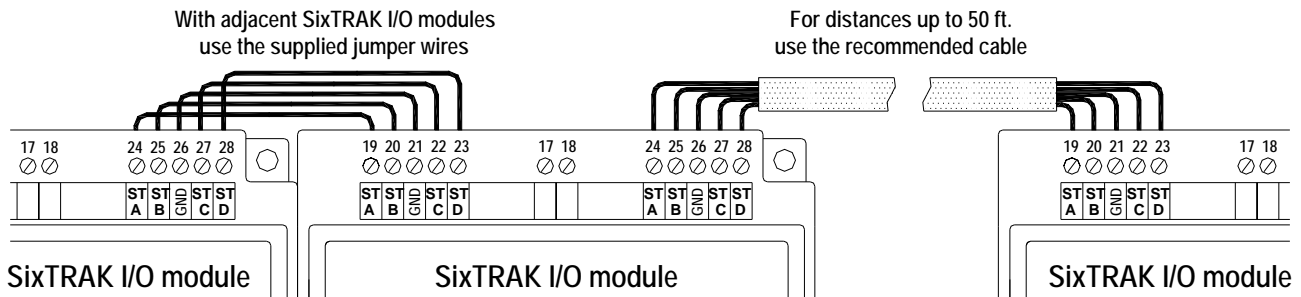

Use the supplied ST-Bus jumpers between adjacent SixTRAK components. Otherwise, use the recommended cable.

Section 4

Communications

Communication ports

RS232 Ports A and B

The SIXNET controllers and RTUs covered by this manual have various combinations of Ethernet and serial ports. See the chart below.

Product	RS232 Port A	RS232 Port B	RS485 Port C	RS232 Port D	Ethernet Port 1	Ethernet Port 2	Built-in Switch
ST-IPM-####	X	X	X	-	X	X	X
VT-IPM-####	X	X	X	X	X	-	-

These ports are identical in connection and functionality. A RJ45 female connector is provided for each. The pin-outs follow the EIA/TIA-561 standard (See figures 4-1 and 4-2). A pre-wired DB9F to RJ45F adapter is included with these units. Use this adapter along with a RJ45 male to RJ45 male straight-thru wired patch cable (not included) to make a connection between a com port on your PC (DB9 male) and either Port A or B (RJ45 female). Refer to the SIXNET Electronic catalog for more information on connecting to other equipment.

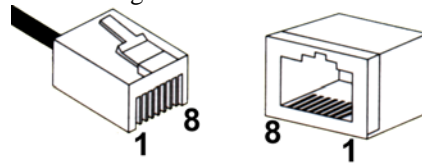

**RJ45 Pin Locations
(for RS232 or Ethernet)**

RS485 Port C

This port is found on all units. It provides a RS485 (2-wire, half duplex only) connection to SIXNET's RemoteTRAK I/O modules or other equipment. Four terminals (for signal gnd, 485+, 485-, & termination) are provided. Generally, you connect + to + and - to - between units. However, since there is no standard for RS485 terminal designations you may need to connect + to - and - to + in some cases. No damage will result if you connect incorrectly. It is highly recommended that you tie the signal ground to an appropriate ground (if available) between all RS485 units. Make sure to use a good quality communication cable with three conductors (twisted is preferred) plus a shield. To prevent ground loops, the shield should be connected to chassis ground on only one end of any cable run.

Note: If you have existing wiring that has only two conductors and a shield, you can use the shield to connect the signal grounds between stations. This is not optimal (especially for long cable runs) but should work in most situations.

RS485 Termination: All these units have RS485 termination components (150 ohm resistor and a 0.1 μ F capacitor connected in series) already inside. To terminate your RS485 network just tie the "T" terminal to the RS485 - terminal. Make sure to use the same type and size conductor as used already used for your RS485 - connection. It is recommended that both end stations of your RS485 network be terminated. Avoid terminating more than two stations. Refer to the RemoteTRAK I/O User Manual on how to terminate a RemoteTRAK I/O Module. For 3rd party devices, please refer to their user manual for termination instructions.

Bias Resistors: On a RS485 2-wire network, a pair of bias resistors (1K ohm typically) acting upon the transmit/receive wires may be required. If bias resistors are not present, the receive inputs on some RS485 devices may react to noise on the floating wires. The bias resistors will force the transmit/receive wires to a known (non-floating) state when none of the RS485 devices are transmitting data. Some RS485 devices have bias resistors built-in, and are enabled through DIP-switch or jumper settings. Make sure there is only one pair of bias resistors acting upon the network.

Note: If your RS485 network is made up exclusively of SIXNET devices then these bias resistors are not necessary.

**RS232
Port D**

This port is found only on the VersaTRAK IPm. Five screw terminals (for TD, RD, RTS, CTS, and GND) are provided to make your connections. Note: The 5th terminal is signal ground and is shared by the adjacent RS485 Port C. Refer to figure 4-2 for the exact connections.

**Ethernet Port 1
(Primary)**

This port is found on all units. It is a 10/100BaseTx auto-detecting and auto-crossover Ethernet port. This means it will auto-detect the speed, and work with either a straight-thru or cross-wired Ethernet cable. A standard shielded RJ45 connector is provided. See the figures below for the pin-outs. This port has a fixed unique MAC address. The IP address can be set with the SIXNET I/O Tool Kit software. Refer to the on-line help for details.

**Ethernet Port 2 with
Built-in Switch**

This port is found on only the SixTRAK IPm. It is internally tied to an industrial Ethernet switch (equivalent to SIXNET's ET-GT-5ES-1). This provides four switched ports (standard shielded RJ45 connectors) to connect to peripheral equipment such as SIXNET's EtherTRAK Ethernet I/O modules. All are 10/100BaseTx auto-detecting and auto-crossover Ethernet ports. This means they will auto-detect the speed, and work with either a straight-thru or cross-wired Ethernet cable. This port has a fixed unique MAC address. The IP address can be set with the SIXNET I/O Tool Kit software. Refer to the on-line help for details.

Note: The primary Ethernet port is not internally tied to the internal Ethernet switch or the second Ethernet port. The first and second Ethernet ports act independently from each other. Refer to the SIXNET Electronic Help system for more details and usage tips.

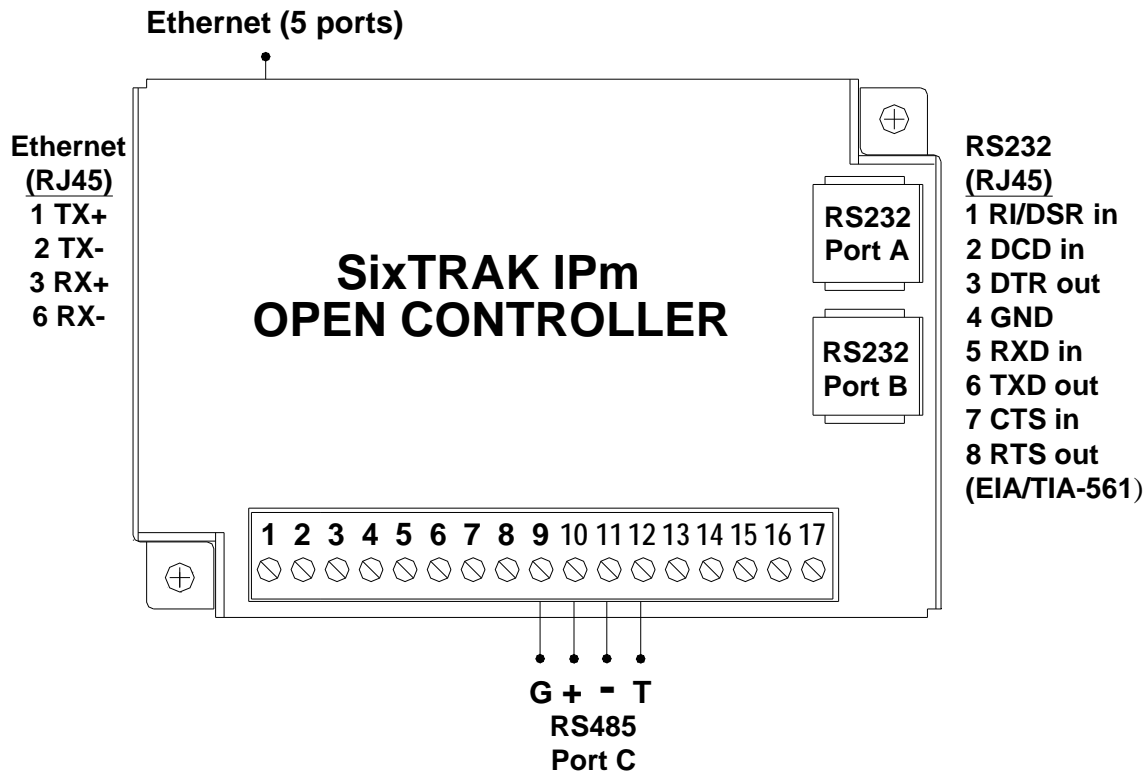

SixTRAK IPm Communication Connections (Figure 4-1)

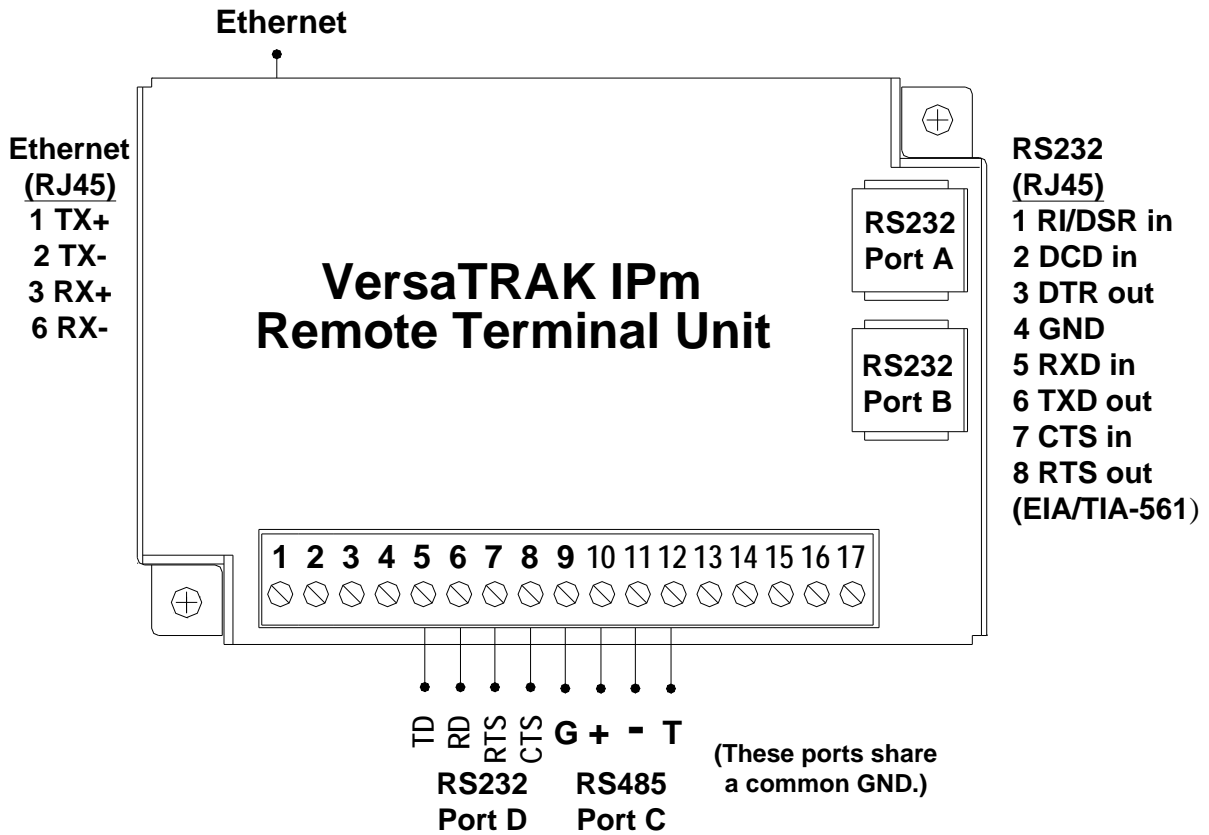

VersaTRAK IPm Communication Connections (Figure 4-2)

Section 5 Technical Specifications

Technical Specifications

Here are the technical specifications for the SixTRAK IPm Open Controller, VersaTRAK IPm RTU, and SixTRAK I/O.

General	Industrial PowerPC (32 bit data bus)
Compatibility with legacy VersaTRAK RTU and SixTRAK Programmable I/O Gateway	Fully (except there is no on-board I/O)
Operating system	Embedded LINUX
Unique station addresses (unit Ids)	16,000+ (SIXNET) or 247 (Modbus)
Dynamic memory (RAM) (for program execution, dynamic variables, dynamic file system, etc.)	32bit, 0 wait states xT-IPM-1### → 16 Megabytes xT-IPM-2### → 16 Megabytes xT-IPM-6### → 64 Megabytes
Program memory (Flash) (for Linux OS, program storage, and file system)	xT-IPM-1### → 16 Megabytes xT-IPM-2### → 16 Megabytes xT-IPM-6### → 16 Megabytes
Additional Flash memory	xT-IPM-6### → 128 Megabytes
Datalogging memory (RAM) (for datalogging and retained variables)	Battery-backed – Rechargeable Lithium xT-IPM-1### → 512K bytes xT-IPM-2### → 2 Megabytes xT-IPM-6### → 2 Megabytes
Battery-backup time / life	1 year / 10+ years
Real-time clock resolution	10 mS
Real-time clock accuracy	+/-15 seconds per month
I/O expansion	SixTRAK, EtherTRAK, RemoteTRAK
Maximum local I/O (via ST-Bus port)	1,024 (128 SixTRAK modules) (expander required after every 20 modules)
Maximum distributed I/O (application dependent)	50,000+
Datalogging support	Yes – SIXNET Sixlog
Datalogging modes	Trending, alarm logging, sequence of events, event initiated, client transfers, and others
LINUX capabilities	Practically unlimited (standard option for ST-IPm and VT-IPm) (OEM only option for ST-GT-####)
Programming	High level C and others
Number of applications allowed	As many as there is memory for
Available FREE source code	Practically unlimited
IEC 61131 PLCopen programming	Yes – SIXNET ISaGRAF
Languages supported	Ladder logic, function chart, function block, instruction list, structured text, and flow chart
Number of programs allowed to be run in IPm at same time	1 for ST-GT-#### 2 for VT-IPM-#### 4 for ST-IPM-####
Cycle time	10 mS minimum (user settable)
Communication capabilities	Master, slave, peer to peer, report on exception, store and forward and more
Communication media supported	Ethernet, telemetry, telephone (dialup and leased line), radio (dumb and smart), other wireless, fiber optic, short haul and more

Redundancy	Various levels supported
Redundant Ethernet links (ST-IPm only)	Yes – 2 unique MAC & IP addresses allow for 2 unique network connections
Redundant I/O modules	Yes – multiple modules can interface to the same I/O; an internal discrete bit reports on-line status of each module
Redundant controllers	Yes – automatic controller switch-over is supported (user application programming required)
Redundant power inputs (ST-IPM and VT-IPM only)	Yes – automatic switch-over on failure
Backup RS485 communications	Yes – especially with EtherTRAK modules
Watchdogs and Monitors	For run-time diagnostics
CPU watchdog	CPU automatically resets if error is detected; status LED flashes error code
Communications watchdog	Settable timeout and output action (force off or freeze)
Heartbeat watchdog	Settable timeout & output action (force off or freeze)
Ethernet Port(s)	10/100BaseTx (auto-detecting)
Connection	RJ45 (auto-crossover)
Isolation	1500 Volts RMS 1 minute (60 Hz.)
Message response time (typical)	5 mS
Diagnostic LEDs on each port	Indicates speed, link and activity
Protocols supported	TCP/IP, ARP, UDP, ICMP, DHCP, Modbus/TCP, SIXNET, and more
Independent networks	VT-IPm & ST-GT = 1 w/ unique MAC & IP address ST-IPm = 2 w/ unique MAC & IP addresses
Network port 1	1 shielded RJ45 connector
Network port 2 (ST-IPm only)	4 shielded RJ45 connectors (linked via integrated Ethernet switch)
Integrated Ethernet switch features	Same as SIXNET's ET-GT-5ES-1
Serial Ports	300 to 115,200 baud
RS232 Port A	RJ45 (TD, RD, CTS, RTS, CD, DTR, DSR/RI, GND)
RS232 Port B	RJ45 (TD, RD, CTS, RTS, CD, DTR, DSR/RI, GND)
RS485 Port C	Screws (GND, 485+, 485-, termination) (2-wire half-duplex) (GND common with port D)
RS485 network	Up to 32 (full-load) stations
RS485 distance	Up to 0.5 miles (1 km)
RS232 Port D (VT-IPm only)	Screws (TD, RD, RTS, CTS, GND)
Protocols (master & slave)	SIXNET & Modbus (RTU and ASCII); Many others available in LINUX
Diagnostic LEDs on each port	Transmit Data (TD) & Receive Data (RD)
Flow Control	Hardware, software, RTS-party (for radios and RS485)
ST-BUS (local I/O) port	Full line of analog and discrete I/O
Modules	Up to 128 (including expanders)
I/O channels	Up to 1,024
Scan time	5 mS minimum (varies depending on quantity and type of I/O modules)
Benchmark 1: 48 discretes & 8 analog	10 mS
Benchmark 2: 512 discretes	30 mS
Benchmark 3: 128 analogs	40 mS
Benchmark 3: 512 discretes & 128 analogs	80 mS

Cable length	50 ft. (16 m.)
Wiring configurations	Daisy-chain or star
Cable type required	2 individually shielded pairs, 22 AWG min.
I/O Tool Kit Windows Software	Level 1 provided free with all systems
Operating systems	95, 98, ME, NT, 2000, and XP
Minimum system requirements	Pentium or equivalent, 32 Mb RAM, 100 Mb hard disk space
Option 1 (Basic)	Configuration, calibration, diagnostics, and limited exporting of I/O definitions.
Option 2 (SCS)	Full importing and exporting of I/O definitions, peer to peer I/O transfers, and the IOMap shared database.
Option 3 (Datalogging)	Datalogging capability and quick load feature "Load All".
Option 4 (LINUX)	LINUX functionality and support.
Option 5 (Web Server)	Web Server functionality and support.
Environmental	DIN rail or flat panel mount
Input voltage	10-30 VDC (integrated switching supply), (External AC/DC or DC/DC supplies optional)
Input power (@ 24 VDC unless otherwise noted) (+/-10%) (Note: The power consumption variations mostly depend on the number of Ethernet and/or serial connections.)	VT-IPm: 2.4 W (110 mA) – typical (no communications) 2.7 W (112 mA) – typical (serial communications only) 3.1 W (128 mA) – typical (all ports communicating) (rated current at max. voltage 30 VDC is 125 mA) ST-IPm: 3.8 W (159 mA) – typical (no communications) 4.6 W (190 mA) – typical (some serial and Ethernet coms.) 5.3 W (220 mA) – typical (all ports communicating) (rated current at max. voltage 30 VDC is 175 mA)
Redundant power inputs	Yes with automatic switch over, diode protection, and internal voltage monitoring
Temperature	-40 to 70°C (-40 to 85°C storage)
Humidity	5% to 95% RH (non-condensing) (optional conformal coating)
Flammability	UL 94V-0 materials
Electrical Safety	UL 508, CSA C22.2/14; EN61010-1 (IEC1010); CE
EMI emissions	FCC part 15, ICES-003, Class A; EN55022; EN61326-1; CE
EMC immunity	EN61326-1 (EN61000-4-2,3,4,6); CE
Surge withstand	IEEE-472 (ANSI C37.90); EN61000-4-2, 4
Vibration	IEC68-2-6
Hazardous locations (Class 1, Div 2, Groups A, B, C, D)	UL 1604, CSA C22.2/213, Cenelec EN50021 Zone 2
Marine & Offshore	DNV (Det Norske Veritas)
Packaging	Alum. cover (iridite finish) on Lexan base
Mounting	DIN rail (EN50022) or direct to panel
Size	VT-IPm → 4.75"L x 3.25"W x 2.65"H (121mm x 83mm x 67mm) ST-IPm → 4.75"L x 3.25"W x 3.15"H (121mm x 83mm x 80mm)
Weight	VT-IPm → 0.730 Lbs. ST-IPm → 0.840 Lbs.

Section 6

Maintenance Information

Local Diagnostics

Local diagnostics can be performed through any available port while the controller or RTU is responding to messages from the other port. Diagnostic software, such as the SIXNET I/O Tool Kit, can be used to display the status of the I/O registers. Refer to the software's on-line help for details.

Status LED

The "Status" LED on the controller or RTU indicates its operational status:

ON

The controller or RTU is operating properly.

OFF

There is no power to the controller or RTU or service is required. Contact SIXNET technical support.

FAST BLINK

This may occur when the controller or RTU is being reset, or firmware is to be downloaded from the I/O Tool Kit software.

SLOW or PERIODIC BLINK

This indicates that the internal watchdog has detected a problem. Try clearing the memory and reloading the project from the I/O Tool Kit.

Controller or RTU Memory

These SIXNET controllers and RTUs have nonvolatile (battery-free) memory for storing configuration data from the I/O Tool Kit utility.

They also have battery-backed memory for storage of program variables and logged data. The battery is a rechargeable lithium cell that is kept fresh by the power circuitry in the controller or RTU. The memory retention period for an unpowered controller or RTU is at least 6-months at room temperature. The retention time will be shorter at higher temperatures. The life expectancy of the lithium battery is approximately 10 years or more.

Product Support

To obtain support for SIXNET products, call SIXNET and ask for Applications Engineering. Our phone numbers are:

Phone: +1 (518) 877-5173

Fax: +1 (518) 877-8346

E-mail: support@sixnet.com

Visit us on the Web: www.sixnet.com

Our mailing address:

SIXNET

331 Ushers Road

Ballston Lake, NY 12019

Section 7

Service Information

Warranty Information

The warranty for SIXNET products is stated previously in this manual.

Service Information

We sincerely hope that you never experience a problem with any SIXNET product. If you do need service, call SIXNET at (518) 877-5173 and ask for Applications Engineering. A trained specialist will help you to quickly determine the source of the problem. Many problems are easily resolved with a single phone call. If it is necessary to return a unit to us, an RMA (Return Material Authorization) number will be given to you.

SIXNET tracks the flow of returned material with our RMA system to ensure speedy service. You must include this RMA number on the outside of the box so that your return can be processed immediately.

The applications engineer you are speaking with will fill out an RMA request for you. If the unit has a serial number, we will not need detailed financial information. Otherwise, be sure to have your original purchase order number and date purchased available.

We suggest that you give us a repair purchase order number in case the repair is not covered under our warranty. You will not be billed if the repair is covered under warranty.

Please supply us with as many details about the problem as you can. The information you supply will be written on the RMA form and supplied to the repair department before your unit arrives. This helps us to provide you with the best service, in the fastest manner. Normally, repairs are completed in two days. Sometimes difficult problems take a little longer to solve.

If you need a quicker turnaround, ship the unit to us by air freight. We give priority service to equipment that arrives by overnight delivery. Many repairs received by mid-morning (typical overnight delivery) can be finished the same day and returned immediately.

We apologize for any inconvenience that the need for repair may cause you. We hope that our rapid service meets your needs. If you have any suggestions to help us improve our service, please give us a call. We appreciate your ideas and will respond to them.

For Your Convenience:

Please fill in the following and keep this manual with your SIXNET system for future reference:

P.O. #: _____ Date Purchased: _____

Purchased From: _____