

PROTECTED TECHNOLOGY POLICY

SIXNET protects your investment in SIXNET systems with long-term planned technology and our unique Protected Technology Policy. We will continue to support the specified capabilities of standard SIXNET products for at least five years. We plan each product improvement and new feature to be upward compatible with existing designs and installations. Our goals are to make each new software release bring new power to your SIXNET systems and have every existing feature, applications program and data file continue to work.

We protect your investment even further with a liberal five-year trade-in policy. Exchange standard products for upgraded versions of the same product to take advantage of new features and performance improvements at any time for five years. A prorated trade-in allowance will be given for your existing equipment.

SIXNET protects your long-term productivity with state-of-the-art planned technology and continued support.

STATEMENT OF LIMITED WARRANTY

SIXNET, manufacturer of SixTRAK, VersaTRAK, RemoteTRAK and EtherTRAK products, warrants to Buyer that products manufactured by SIXNET will be free from defects in material and workmanship. SIXNET's obligation under this warranty will be limited to repairing or replacing, at SIXNET's option, the defective parts within 1 year of the date of installation, or within 18 months of the date of shipment from the point of manufacture, whichever is sooner. Products may be returned by Buyer only after permission has been obtained from SIXNET. Buyer will prepay all freight charges to return any products to the repair facility designated by SIXNET.

This limited warranty does not cover losses or damages that occur in shipment to or from Buyer or due to improper installation, maintenance, misuse, neglect or any cause other than ordinary commercial or industrial applications. This limited warranty is in lieu of all other warranties whether oral or written, expressed or implied. SIXNET's liability shall not exceed the price of the individual unit which is the basis of the claim. In no event shall SIXNET be liable for any loss of profits, loss of use of facilities or equipment or other indirect, incidental or consequential damages.

INSTALLATION AND HAZARDOUS AREA WARNINGS

These products should not be used to replace proper safety interlocking. No software-based device (or any other solid-state device) should ever be designed to be responsible for the maintenance of consequential equipment or personnel safety. In particular, SIXNET disclaims any responsibility for damages, either direct or consequential, that result from the use of this equipment in any application.

All power, input and output (I/O) wiring must be in accordance with Class I, Division 2 wiring methods and in accordance with the authority having jurisdiction.

WARNING – EXPLOSION HAZARD – SUBSTITUTION OF COMPONENTS MAY IMPAIR SUITABILITY FOR CLASS 1, DIVISION 2.

WARNING – EXPLOSION HAZARD – WHEN IN HAZARDOUS LOCATIONS, DISCONNECT POWER BEFORE REPLACING OR WIRING MODULES.

WARNING – EXPLOSION HAZARD – DO NOT DISCONNECT EQUIPMENT UNLESS POWER HAS BEEN SWITCHED OFF OR THE AREA IS KNOWN TO BE NONHAZARDOUS.

<p>Note: All information in this document applies to the Mini-VersaTRAK mIPm RTU, except where otherwise noted. Refer to the electronic help system in the SIXNET I/O Tool Kit software for detailed product specifications and configuration settings.</p>
--

Following these steps will make installation and start-up easier.

① Mount the Hardware

If you purchased a TrakPak packaged system, the complete enclosure is ready for installation on any flat surface. If you purchased individual components, refer to the following sections of this manual or other appropriate user manuals for information on installing them into an enclosure. (See Section 2 for further details)

② Install Communication Wiring to I/O Modules

Make the necessary communication connections to any EtherTRAK I/O, RemoteTRAK I/O, or 3rd party devices. If you have a TrakPak packaged system, many of these connections have already been done for you. Otherwise, refer to the I/O module manuals as needed to establish the correct physical connections with the VT-MIPM.

③ Connect Power and I/O Wiring to On-board I/O and I/O Modules

Connect AC power to the SIXNET or user supplied power supply. Make DC power connections from the power supply to the SIXNET components. Make field wiring connections to the SIXNET I/O modules and any peripheral equipment. Refer to the VT-MIPM power / wiring diagram (Figure 3-3) for making the appropriate power and on-board I/O connections.

④ Install Communication Cabling

The units covered by this manual come with communication accessories. Snap the pre-wired RJ45 to DB9 adapter to the RJ45 patch cord (not supplied). Connect this cable between one of the serial RS232 ports (RJ45 connector) on your RTU and a serial RS232 port (DB9 connector) on your PC. More details about Ethernet, RS232 and RS485 wiring are provided in Section 4.

Fabricate and install RS232 and RS485 cables as needed to connect to other devices. If you are using Ethernet units, install the correct cabling and peripherals. Refer to the documentation for your Ethernet communication devices for details.

⑤ Apply Power

Power up the SIXNET components and related peripherals. Observe the PWR LED on the RTU. A solid ON indicates proper operation. The Status LED on EtherTRAK and RemoteTRAK I/O modules should be ON solid or blinking, depending on whether I/O Transfers have been configured in the RTU. Refer to the appropriate SIXNET user manual for PWR/Status LED details.

⑥ Configure Using the SIXNET I/O Tool Kit

Use the SIXNET I/O Tool Kit to create a hardware configuration for each SIXNET station. Refer to the electronic help in the I/O Tool Kit for details.

⑦ Test the Hardware

Use the Test I/O window in the I/O Tool Kit program to verify proper I/O operation of all SIXNET stations. Refer to the I/O Tool Kit electronic help system.

⑧ Configure Your PC Software to Communicate with the SIXNET station(s)

Refer to the documentation for your software.

⑨ If You Have Difficulty

If you experience startup trouble, refer to Section 6 in this document for some troubleshooting tips or go to www.sixnet.com. If you still need assistance then please contact SIXNET.

SIXNET Software Tools



SIXNET I/O Tool Kit

SIXNET supplies the "mission oriented" tools you need for every step of your project from the initial specification, through startup, and years of trouble free operation. Configuration information flows between SIXNET Windows, saving you time (you don't have to enter data multiple times) and dramatically reducing data entry errors. Refer to the electronic help in the SIXNET I/O Tool Kit for complete details.

The SIXNET I/O Tool Kit is a configuration, calibration and maintenance tool for SIXNET hardware. Use the I/O Tool Kit to configure I/O features, perform channel-by-channel calibrations in meaningful engineering units, and perform live diagnostics at each station. Refer to the electronic help for details.

Here are some of the optional Feature Sets for the SIXNET I/O Tool Kit:

SCS (Scalable Control System) features

Includes importing, tag exporting, I/O transfers and advanced load options. The SCS option is required to develop ISaGRAF programs using the ISaGRAF Workbench.

Datalogging

Includes Sixlog datalogging (see below) with host transfer and client transfer capability.

Open LINUX features

Gain access to LINUX-visible features in IPm controllers, including file loading and advanced diagnostics. A library of functions to access the IPm I/O registers and other services is supplied with this enhanced license.



Sixlog

Sixlog is datalogging software for SIXNET controllers and RTUs. Data is logged into protected memory in the unit. Then Sixlog uploads the data files and saves them into ASCII format files that are easy to import into databases, spreadsheets and other Windows applications. Access the Sixlog functions from within the SIXNET I/O Tool Kit.



ISaGRAF

The ISaGRAF Workbench allows you to write an IEC 61131 control program for a SIXNET controller or RTU. All six of the IEC 61131 languages are supported, including Ladder Logic and Function Blocks.

Using SIXNET Windows Software



Below is a quick overview of using the SIXNET I/O Tool Kit. It is supplied on the SIXNET CD. Registration for Level 1 (basic features) is free of charge.

Note: An expanded version of this page has been provided as electronic help. To access it, click on the Getting Started icon in the I/O Tool Kit electronic help.

Basic Configuration: Run the SIXNET I/O Tool Kit program and create your panel layouts. Then configure the operating parameters for each SIXNET component, including channel tag names. Assign virtual I/O modules and I/O transfers for any EtherTRAK or RemoteTRAK modules you wish to have the RTU poll. Once you are satisfied with your configuration, load your configuration to the RTU. Save this information to a project file. Using the Test I/O function, verify that you can read and write all your I/O.

Note: Set tag name restrictions in the SIXNET I/O Tool Kit program before creating tag names to ensure compatibility when exporting them for usage in other Windows applications.

Your SIXNET components are now ready to exchange I/O data with your Windows applications via DDE, OPC, or direct DLL calls. (Refer to the "How to Access SIXNET I/O From a Windows Application" topic in the SIXNET I/O Tool Kit help system.) If you will be running a Windows application, then continue with the following steps.



Exporting I/O Definitions: (optional, requires the SCS feature set) Some Windows applications such as ISaGRAF, Citect and Intellution FIX, can import SIXNET tag names. If your Windows application supports this feature, run the SIXNET I/O Tool Kit and open your project file. Export your tag names to a file using the appropriate format.

Note: If you are exporting tag names for ISaGRAF, Citect or Intellution, you must create, or already have, a project to export tag data into.



Datalogging: (optional, requires the Datalogging feature set) If you will be logging data in the SIXNET RTU, then create the appropriate datalog configuration(s) and load them into the unit. Refer to the Sixlog topics in the SIXNET I/O Tool Kit help system for details.



IEC 61131 Programming: (optional, requires the SCS feature set) If you are using the ISaGRAF IEC1131 programming software, refer to the SIXNET ISaGRAF help system for detailed instructions.



LINUX capabilities: (optional, requires the IPm Advanced feature set) If you are using the advanced LINUX IPm capabilities, refer to the SIXNET I/O Tool Kit help for detailed instructions. IPm Advanced documentation and compilers are available for download from www.sixnet.com.

Section 2

Assembly and Installation

Panel Assembly

Most SIXNET components snap onto DIN rail strips fastened to a subpanel. Figure 2-1 shows a sample panel with DIN rail strips and wire duct attached. Recommended DIN rail spacing is 8 inches. This spacing allows room for wire duct to be installed without obstructing field wiring installation.

The SIXNET components are typically installed against one another, but space may be left between modules to accommodate other DIN rail mounted components such as terminal blocks and fuse holders. End clamps are recommended to restrict side-to-side movement. Figure 2-2 shows the physical dimensions of the VT-MIPM.

SIXNET components can be installed in any orientation and order on your panel.

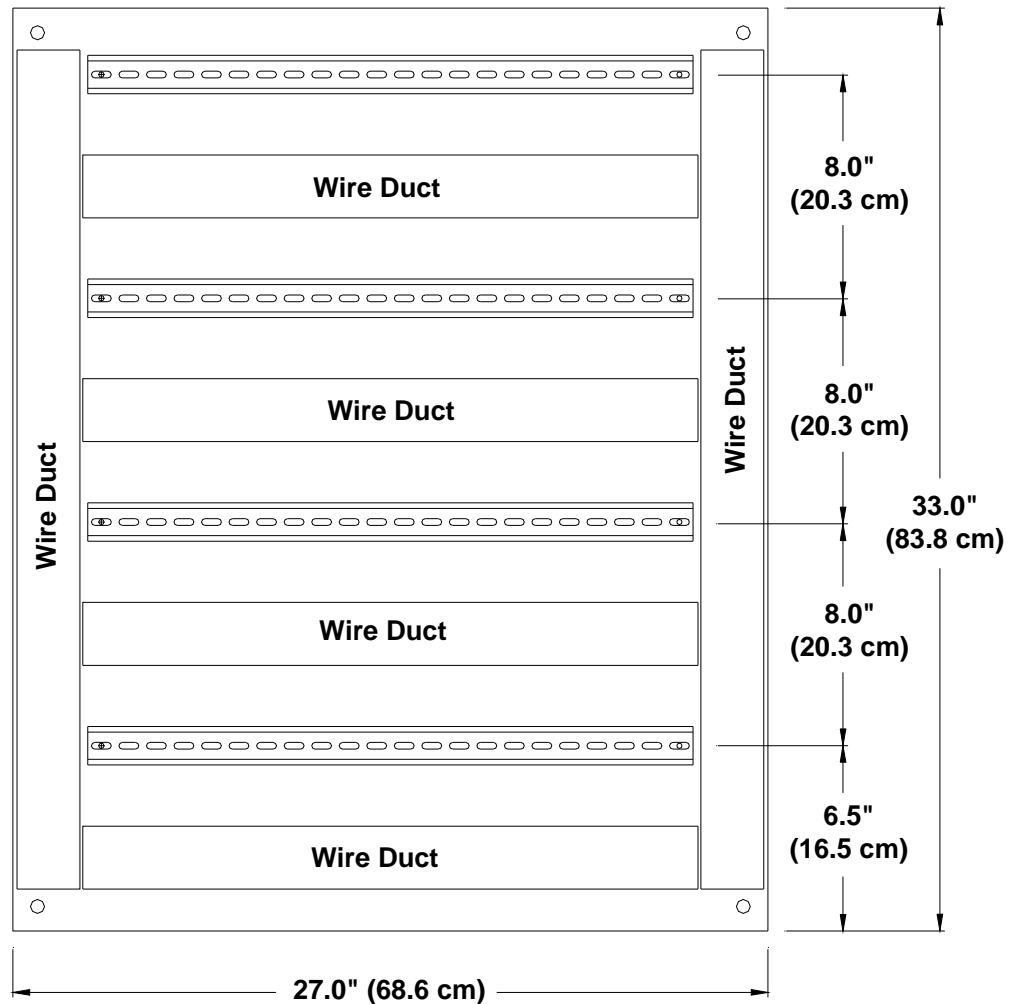

Sample Layout For a 36" x 30" Enclosure
(Figure 2-1)

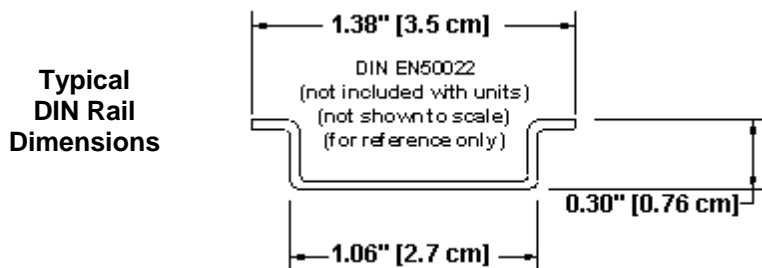
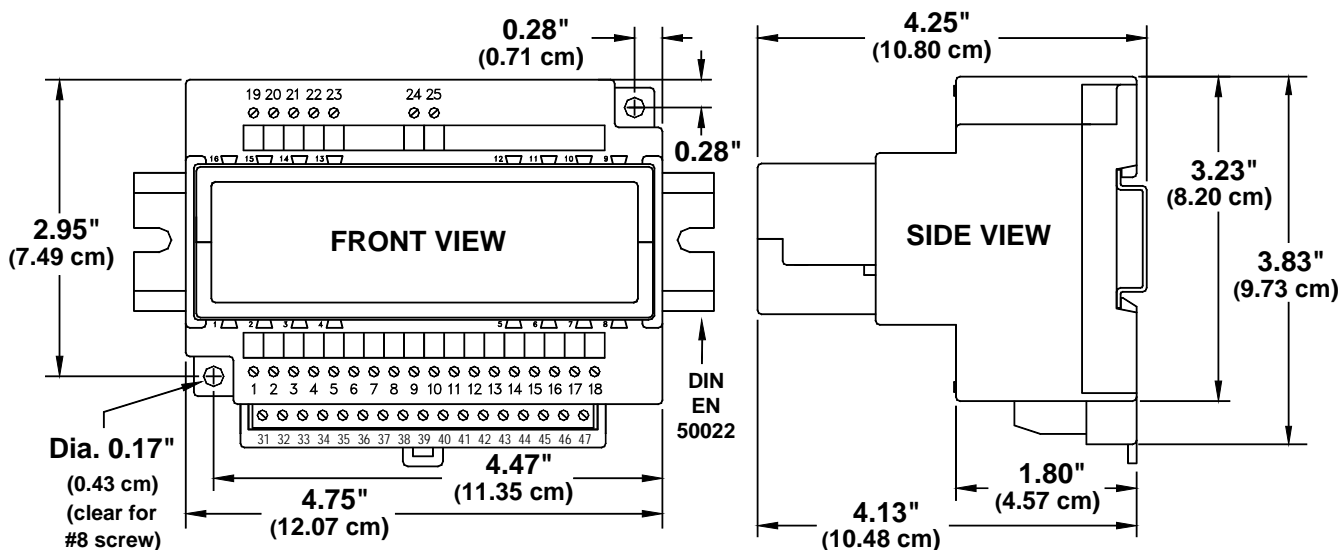

Mini-VersaTRAK mIPm RTU Dimensions
(Figure 2-2)

Section 3 Power and I/O Wiring

Power Requirements

ST-PS-024-02N (24VDC @ 2A)

The SIXNET Mini-VersaTRAK mIPm RTU accepts 24 VDC power from a SIXNET power supply or from a user DC power source of **10 to 30 VDC**. The SIXNET ST-PS-024-02N provides 24VDC @ 2A. The SIXNET RM-PS-024-01F provides 24VDC @ 1A.

The SixTRAK power supply operates on 90 to 260VAC (47 to 63 Hz.). Refer to Figure 3-1 for connections. Tighten these screw terminals to a maximum of 3.48 in.-lbs.

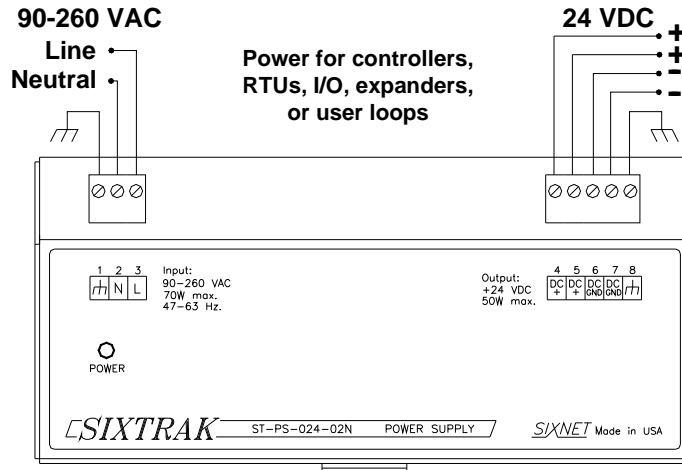

ST-PS-024-02N Power Connections

(Figure 3-1)

RM-PS-024-01F (24VDC @ 1A)

The RM-PS-024-01F operates on 85-264 VAC (47-63 Hz) or 120-370 VDC. Refer to Figure 3-2 for connections. Tighten the screw terminals to a maximum of 3.48 in.-lbs.

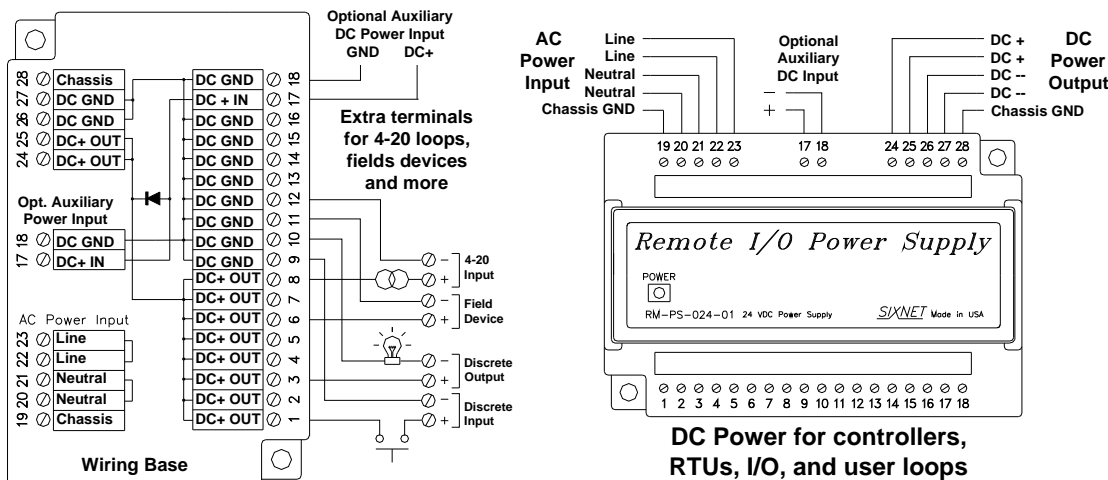

RM-PS-024-01F Power Connections

(Figure 3-2)

RM-PS-024-01F Redundant Power

The RM-PS-024-01F allows you to connect auxiliary 24 VDC power (from another RM-PS-024-01F or other source) to terminals 17 and 18. When auxiliary power is connected, the RM-PS-024-01F will source most of the power under normal operating conditions. If the primary power fails then the auxiliary power will immediately take over.

Current Requirements

To calculate the current requirements, add the wattage required for the Mini-VT-MIPM and other modules in use. Then divide the total wattage by the DC power source voltage. Then add any current needed for user instrumentation loops.

DC Power Wiring

All SIXNET units and user instrumentation loops may be powered from a single DC source. Refer to Figure 3-3 DC power connections to the VT-MIPM. The user DC power source must be in the range of **10 to 30 volts**.

On-board I/O Overview

The VT-MIPM comes with integrated discrete and analog I/O on board. Wiring for the available on-board I/O should be made based on the wiring diagram shown in Figure 3-3. A hardware summary for each of the available I/O is described below. Further details on the features available when using the on-board I/O can be found in the electronic help system in the Sixnet I/O Tool Kit.

Discrete Inputs

There are twelve discrete inputs in all models of the VT-MIPM. These inputs may be wired for sourcing or sinking by selecting the proper DI return jumper position in the base. An input count feature uses analog input registers to accumulate the positive transitions of each input.

Positive DC voltage must be applied to an input to indicate an ON condition. All channels are referenced to a common return or supply, which is connected to the negative side (ground) or positive side (DC+) of the DC power source. One wire from each sourcing field input should be bussed together and connected to terminal 17 (DC +). One wire from each sinking field input should be bussed together and connected to terminal 18 (DC GND). Refer to the wiring diagram, Figure 3-3. Set the DI return jumper inside the wiring base to match the wiring configuration of the inputs (sinking or sourcing).

Discrete Outputs

Depending on your model of the VT-MIPM, there are either four or eight discrete outputs integrated into the unit. The discrete output channels each provide up to 1 Amp DC to power motor contactors, valves, and other loads.

A single terminal is provided for each output channel. All outputs are powered from the DC power terminal. All channels are referenced to a common return, which is connected to the negative side (ground) of the DC power source.

Analog Inputs

There are either six or eight 4-20mA analog inputs on your VT-MIPM. These inputs provide 16 bits of resolution for precision analog measurements.

A single input terminal is provided for each measurement channel. Care must be taken to externally provide a suitable instrumentation ground for these single ended input circuits.

Precision 100 ohm current shunts beneath the hinged access door in the wiring base pass current and maintain loop integrity, even if the plug-in logic module is removed. Each analog channel has built in current protection circuitry, such that each channel open circuits before any circuit damage will occur.

Analog Outputs

The Mini-VersaTRAK mIPm model VT-MIPM-241 has two 4-20mA analog output channels, providing 16 bits of resolution at each channel.

A single terminal is provided for each output channel. Care must be taken to externally provide a suitable instrumentation ground for these output circuits.

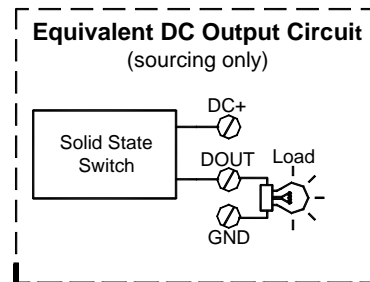
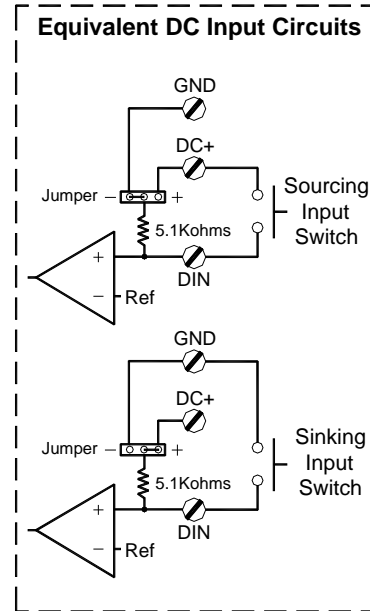
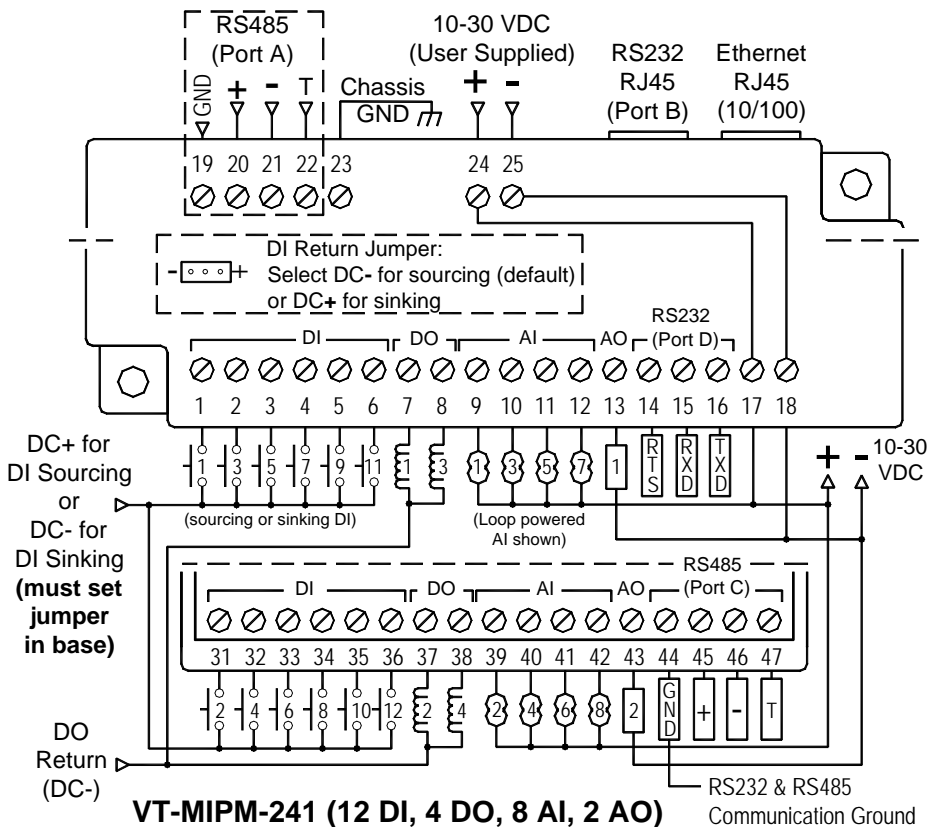
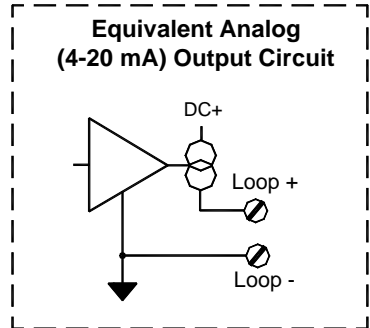
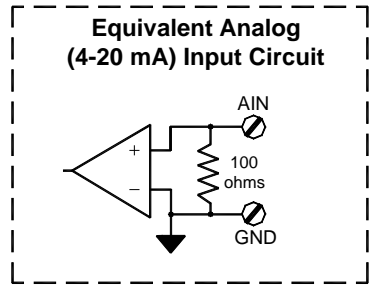
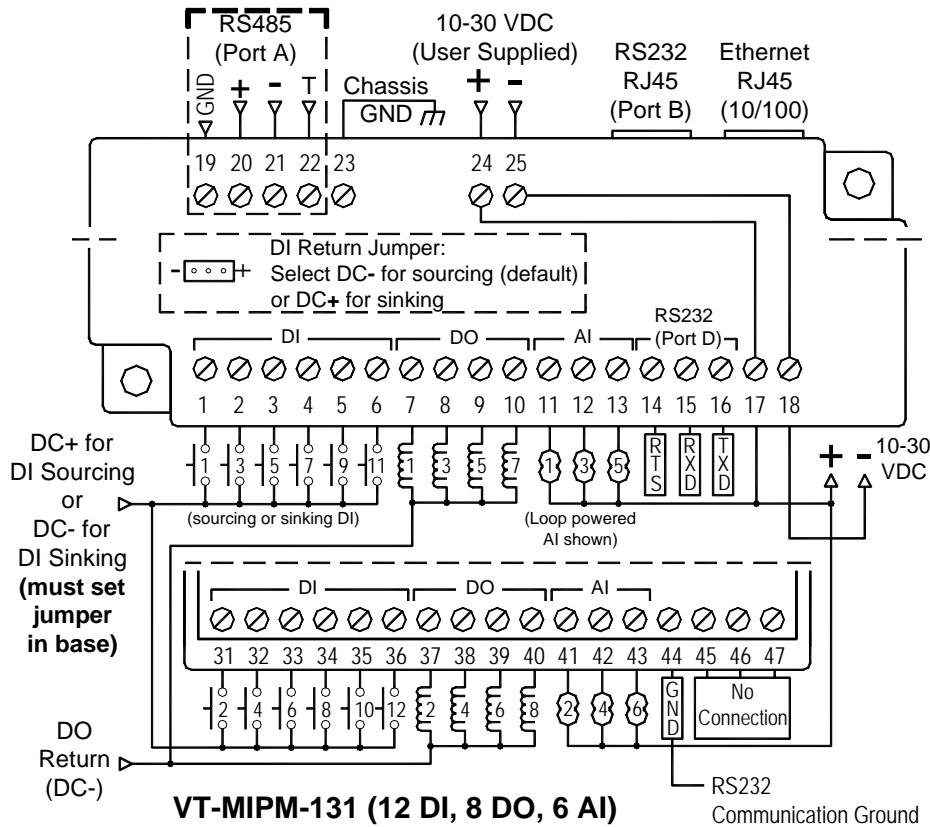

Mini-VersaTRAK mIPm diagram for power, communication, and on-board I/O wiring (Figure 3-3)

Section 4

Communications

Communication ports

The VT-MIPM-XXX has two available port combinations, depending on the model number. See the chart below.

Product R	S485 Port A	RS232 Port B	RS485 Port C	RS232 Port D	Ethernet Port
VT-MIPM-131	√	√	--	√	√
VT-MIPM-241	√	√	√	√	√

RS232 Port B

An RJ45 female connector is provided for this port. The pin-outs follow the EIA/TIA-561 standard (See Figure 4-3). A pre-wired DB9F to RJ45F adapter is included with these units. Use this adapter along with a RJ45 male to RJ45 male straight-thru wired patch cable (not included) to make a connection between a com port on your PC (DB9 male) and Port B (RJ45 female). Refer to the SIXNET I/O Tool Kit help for more wiring information.

When connecting a modem, insert the colored wires of the RJ45 to DB9 male adapter into the appropriate sockets of the DB9 male connector according to the table below. Then plug the adapter's DB9 male connector directly onto the DB9 RS232 port of a VT-MODEM-xxx. Connect a straight-through Ethernet cable between the SIXNET RJ45 port and the RJ45 to DB9 male (modem) adapter.

The RJ45 serial port connector bodies on SIXNET products are metallic and are connected to the Chassis GND terminal. Therefore, shielded cables may be used to provide further protection. To prevent ground loops, the cable shield should be tied to the metal connector body at one end of the cable only.

Typical Modem Adapter Wiring:

SIXNET RJ45F Pin #, Signal Name	RJ45F to DB9M Adapter wire color	SIXNET DB9 Male Connector Pin #, Signal Name
1 RI/DSR in	Blue	9 RI out
2 DCD in	Orange	1 DCD out
3 DTR out	Black	4 DTR in
4 GND	Red	5 GND
5 RXD in	Green	2 RXD out
6 TXD out	Yellow	3 TXD in
7 CTS in	Brown	8 CTS out
8 RTS out	White	7 RTS in

Typical PC Adapter Wiring:

SIXNET RJ45F Pin #, Signal Name	RJ45F to DB9F Adapter wire color	DB9 Female Connector Pin #, Signal Name
1 RI/DSR in	Blue	4 DTR out
2 DCD in	Orange	N/C
3 DTR out	Black	6 DSR in
4 GND	Red	5 GND
5 RXD in	Green	3 TXD out
6 TXD out	Yellow	2 RXD in
7 CTS in	Brown	7 RTS out
8 RTS out	White	8 CTS in

RS232 Port D

Port D is a four wire RS232 port. RTS, RXD, TXD and GND terminals are provided. (The

CTS signal is not supported on this Port D.) Depending on your application, you may wish to wire the interface (see Figure 4-3) with a DB9 male or DB9 female connector.

Figure 4-1 shows the pin-outs of male and female DB9 connectors.

Note: The 5th terminal is a communications ground and is shared by the adjacent RS485 Port C for the VT-MIPM-241.

There are two ways to connect Port D to a PC:

1. Make connections from the mIPm screw terminals to a DB9F (female) connector and plug the female connector directly onto your PC.
2. Make connections from the mIPm screw terminals to a DB9M (male) connector and plug the male connector onto one end of a Plant Floor RS232 cable (part number ST-CABLE-PF). Then plug the other end of the ST-CABLE-PF onto your PC. This wiring method allows you to plug the DB9M directly onto a VT-MODEM-xxx as well.

Make connections from the screw terminals of the VT-MIPM-xxx to a DB9 male or DB9 female connector according to table 4-1 below.

VT-MIPM-xxx-D Port D Terminal #	DB9M to ST-CABLE-PF or VT-MODEM-xxx Pin #, Signal Name	DB9F to PC Com Port Pin #, Signal Name
44 GND	5 GND	5 GND
15 RXD in	2 RXD	3 TXD
16 TXD out	3 TXD	2 RXD
N/A	8 CTS	7 RTS
14 RTS out	7 RTS	8 CTS

Table 4-1

"Pin Insertion" side of the DB9M

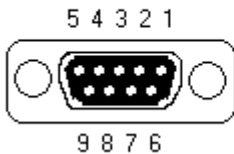

Figure 4-1

"Pin Insertion" side of the DB9F

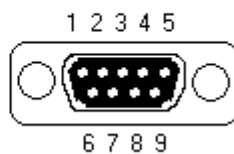
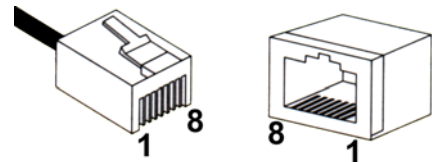

Figure 4-2



RJ45 Connectors

RS485 Port A, C

Depending on the model of Mini VersaTRAK mIPm, there are either one or two RS485 ports available on the unit (See Figure 4-3 for location of these ports). The RS485 port establishes a (2-wire, half duplex only) connection to SIXNET's RemoteTRAK I/O modules or other equipment. Four terminals (for signal GND, 485+, 485-, & termination) are provided for each available RS485 interface. Generally, you connect + to + and - to - between units. However, since there is no standard for RS485 terminal designations you may need to connect + to - and - to + in some cases. No damage will result if you connect incorrectly. It is highly recommended that you tie the signal ground to an appropriate ground (if available) between all RS485 units. Make sure to use a good quality communication cable with three conductors (twisted is preferred) plus a shield. To prevent ground loops, the shield should be connected to chassis ground on only one end of any cable run.

Note: If you have existing wiring that has only two conductors and a shield, you can use the shield to connect the signal grounds between stations. This is not optimal (especially for long cable runs) but should work in most situations.

RS485 Termination: The Mini VersaTRAK mIPm has RS485 termination components (150

ohm resistor and a 0.01 μ F capacitor connected in series) already inside for each RS485 port. To terminate your RS485 network just tie the “T” terminal to the RS485 ‘-’ terminal. Make sure to use the same type and size conductor as used already used for your RS485 ‘-’ connection. It is recommended that both end stations of your RS485 network be terminated. Avoid terminating more than two stations. Refer to the RemoteTRAK I/O User Manual on how to terminate a RemoteTRAK I/O Module. For 3rd party devices, please refer to their user manual for termination instructions.

Bias Resistors: On a RS485 2-wire network, a pair of bias resistors (1K ohm typically) acting upon the transmit/receive wires may be required. If bias resistors are not present, the receive inputs on some RS485 devices may react to noise on the floating wires. The bias resistors will force the transmit/receive wires to a known (non-floating) state when none of the RS485 devices are transmitting data. Some RS485 devices have bias resistors built-in, and are enabled through DIP-switch or jumper settings. Make sure there is only one pair of bias resistors acting upon the network.

Note: If your RS485 network is made up exclusively of SIXNET devices then these bias resistors are not necessary.

Ethernet Port

This port is a 10/100BaseTx auto-detecting and auto-crossover Ethernet port (see Figure 4-2 for RJ45 Pin locations). This means it will auto-detect the speed, and work with either a straight-thru or cross-wired Ethernet cable. A standard shielded RJ45 connector is provided. See the figures below for the pin-outs. This port has a fixed unique MAC address. The IP address can be set with the SIXNET I/O Tool Kit software. Refer to the electronic help for details.

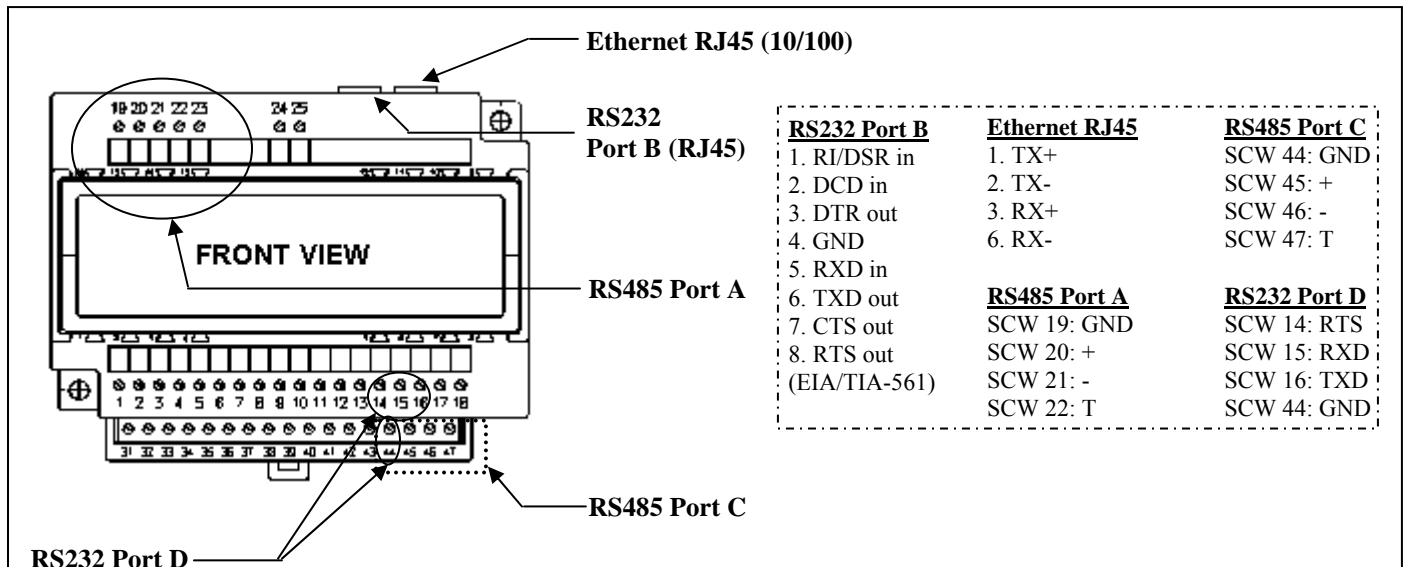

Figure 4-3

Section 5 Technical Specifications

Technical Specifications

Here are the technical specifications for the VersaTRAK mIPm RTU / Controller.

General	Industrial PowerPC (32 bit data bus)
Compatibility with legacy Mini VersaTRAK RTU	Fully compatible with an assortment of on board I/O
Local I/O (on board)	26
Operating system	Embedded LINUX
Unique station addresses (unit Ids)	16,000+ (SIXNET) or 247 (Modbus)
Dynamic memory (RAM) (for program execution, dynamic variables, dynamic file system, etc.)	32bit, 0 wait states 16 Megabytes
Program memory (Flash) (for Linux OS, program storage, and file system)	16 Megabytes
Datalogging memory (RAM) (for datalogging and retained variables)	Battery-backed – Rechargeable Lithium 512K bytes
Battery-backup time / life	1 year / 10+ years
Real-time clock resolution	10 mS
Real-time clock accuracy	+/-15 seconds per month
I/O expansion	EtherTRAK, RemoteTRAK
Maximum distributed I/O	256 physical I/O
Maximum virtual I/O registers	256 per I/O type
Datalogging support	Yes – SIXNET Sixlog
Datalogging modes	Trending, alarm logging, sequence of events, event initiated, client transfers, and others
LINUX capabilities	Practically unlimited
Programming	High level C and others
Number of applications allowed	As many as there is memory for
Available FREE source code	Practically unlimited
IEC 61131 PLCopen programming	Yes – SIXNET ISaGRAF
Languages supported	Ladder logic, function chart, function block, instruction list, structured text, and flow chart
Cycle time	10 mS minimum (user settable)
Communication capabilities	Master, slave, peer to peer, report on exception, store and forward and more
Communication media supported	Ethernet, telemetry, telephone (dialup and leased line), radio (dumb and smart), other wireless, fiber optic, short haul and more

Watchdogs and Monitors	For run-time diagnostics
CPU watchdog	CPU automatically resets if error is detected; status LED flashes error code
Communications watchdog	Settable timeout and output action (force off or freeze)
Heartbeat watchdog	Settable timeout & output action (force off or freeze)
Ethernet Port(s)	10/100BaseTx (auto-detecting)
Connection RJ45	(auto-crossover)
Isolation	1500 Volts RMS 1 minute (60 Hz.)
Message response time (typical)	5 mS
Diagnostic LEDs	Indicates speed and activity
Protocols supported	TCP/IP, ARP, UDP, ICMP, DHCP, Modbus/TCP, SIXNET, and more
Network port	1 shielded RJ45 connector
Serial Ports	300 to 115,200 baud
RS232 Port B	RJ45 (TD, RD, CTS, RTS, CD, DTR, DSR/RI, GND)
RS232 Port D	RJ45 (TD, RD, RTS, GND)
RS485 Port A, C	Screws (GND, 485+, 485-, termination) (2-wire half-duplex) (Port C GND common with port D)
RS485 network	Up to 32 (full-load) stations
RS485 distance	Up to 0.5 miles (1 km)
Protocols (master & slave)	SIXNET & Modbus (RTU and ASCII); Many others available in LINUX
Diagnostic LEDs on each port	Transmit Data (TD) & Receive Data (RD)
Flow Control	Hardware, software, RTS-party (for radios and RS485)
Discrete Inputs	12 Channels
Guaranteed ON Voltage	9 VDC
Maximum Voltage	30 VDC
Guaranteed OFF	5.0 VDC & 1.5mA DC
Input Resistance	10K Ohms
Input Current @ 24V	3 mA
Filtered ON/OFF delay	25ms (20Hz max. counting)
Fast ON/OFF delay	4 ms (100Hz max counting)
Count Rate	(10kHz on channel 1, see above for other rates)
Discrete Outputs	4 or 8 channels (10-30VDC)
Maximum Output per channel	1 Amp
Maximum Output per module	8 Amps
Max. OFF state leakage	0.05 mA
Minimum Load	1 mA
Inrush current	5 Amps (100 ms surge)
Typical ON resistance	0.3 ohms
Typical ON voltage (@1A)	0.3 VDC
Analog Inputs	6 or 8 channels (4-20 mA)
A/D resolution	16 bits (0.003%)
Full scale accuracy	+/- 0.1% (@20°C)
Span and offset temp. coef.	+/- 50 ppm per degree C
Input impedance	100 Ohm
Current protection	Self-resetting fuses
DMRR (differential mode rejection)	66 dB at 50/60 Hz
Analog Outputs	Up to 2 channels (4-20mA)
D/A resolution	16 bits (less than 1µA)
Full Scale accuracy	+/- 0.02%
Span and offset temp. coef.	+/- 50 ppm per °C typical
Max. output settling time	5 ms (to .05%)
Load resistance range (@ +24 VDC supply)	0-750 Ohms
Short circuit protection	Current limiting

I/O Tool Kit Windows Software	Level 1 provided free with all systems
Operating systems	95, 98, ME, NT, 2000, and XP
Minimum system requirements	Pentium or equivalent, 32 Mb RAM, 100 Mb hard disk space
Option 1 (Basic)	Configuration, calibration, diagnostics, and limited exporting of I/O definitions.
Option 2 (SCS)	Full importing and exporting of I/O definitions, peer to peer I/O transfers, and quick load feature "Load All"..
Option 3 (Datalogging)	Datalogging capability and datalog server
Option 4 (LINUX)	LINUX functionality and support.
Environmental	DIN rail or flat panel mount
Input voltage	10-30 VDC (integrated switching supply), (External AC/DC or DC/DC supplies optional)
Input power (@ 24 VDC unless otherwise noted) (+/-10%) (Note: The power consumption variations mostly depend on the number of Ethernet and/or serial connections.)	VT-IPm: 2.4 W (100mA) – typical (no communications)
Temperature	-40 to 70°C (-40 to 85°C storage)
Humidity	5% to 95% RH (non-condensing) (optional conformal coating)
Flammability	UL 94V-0 materials
Electrical Safety	UL 508, CSA C22.2/14; EN61010-1 (IEC1010); CE
EMI emissions	FCC part 15, ICES-003, Class A; EN55022; EN61326-1; CE
EMC immunity	EN61326-1 (EN61000-4-2,3,4,6); CE
Surge withstand	IEEE-472 (ANSI C37.90); EN61000-4-2, 4
Vibration	IEC68-2-6
Hazardous locations (Class 1, Div 2, Groups A, B, C, D)	UL 1604, CSA C22.2/213, Cenelec EN50021 Zone 2
Marine & Offshore	DNV (Det Norske Veritas)
Packaging Lexan	Packaging
Mounting	DIN rail (EN50022) or direct to panel
Size	4.75”L x 3.83”W x 4.13”H (12.07cm L x 9.73cm W x 10.48cm H)

Section 6

Maintenance Information

Local Diagnostics

Local diagnostics can be performed through any available port while the VT-MIPM is responding to messages from the other port. Diagnostic software, such as the SIXNET I/O Tool Kit, can be used to display the status of the I/O registers. Refer to the software's help system for details.

Power and Status LED

ON

The "PWR" LED on the VT-MIPM indicates its operational and power status:

OFF

The VT-MIPM is operating properly.

There is no power to the VT-MIPM or service is required. Contact SIXNET technical support.

FAST BLINK

This may occur when the VT-MIPM is being reset, or firmware is to be downloaded from the I/O Tool Kit software.

SLOW or PERIODIC BLINK

This indicates that the internal watchdog has detected a problem. Try clearing the memory and reloading the project from the I/O Tool Kit.

Controller or RTU Memory

The VT-MIPM has nonvolatile (battery-free) memory for storing configuration data from the I/O Tool Kit utility.

They also have battery-backed memory for storage of program variables and logged data. The battery is a rechargeable lithium cell that is kept fresh by the power circuitry in the VT-MIPM. The memory retention period for an unpowered VT-MIPM is at least 6-months at room temperature. The retention time will be shorter at higher temperatures. The life expectancy of the lithium battery is approximately 10 years or more.

Product Support

To obtain support for SIXNET products, call SIXNET and ask for Applications Engineering. Our phone numbers are:

Phone: +1 (518) 877-5173

Fax: +1 (518) 877-8346

E-mail: support@sixnet.com

Visit us on the Web: www.sixnet.com

Our mailing address:

SIXNET

331 Ushers Road

Ballston Lake, NY 12019

Section 7

Service Information

Warranty Information

The warranty for SIXNET products is stated previously in this manual.

Service Information

We sincerely hope that you never experience a problem with any SIXNET product. If you do need service, call SIXNET at (518) 877-5173 and ask for Applications Engineering. A trained specialist will help you to quickly determine the source of the problem. Many problems are easily resolved with a single phone call. If it is necessary to return a unit to us, an RMA (Return Material Authorization) number will be given to you.

SIXNET tracks the flow of returned material with our RMA system to ensure speedy service. You must include this RMA number on the outside of the box so that your return can be processed immediately.

The applications engineer you are speaking with will fill out an RMA request for you. If the unit has a serial number, we will not need detailed financial information. Otherwise, be sure to have your original purchase order number and date purchased available.

We suggest that you give us a repair purchase order number in case the repair is not covered under our warranty. You will not be billed if the repair is covered under warranty.

Please supply us with as many details about the problem as you can. The information you supply will be written on the RMA form and supplied to the repair department before your unit arrives. This helps us to provide you with the best service, in the fastest manner. Normally, repairs are completed in two days. Sometimes difficult problems take a little longer to solve.

If you need a quicker turnaround, ship the unit to us by air freight. We give priority service to equipment that arrives by overnight delivery. Many repairs received by mid-morning (typical overnight delivery) can be finished the same day and returned immediately.

We apologize for any inconvenience that the need for repair may cause you. We hope that our rapid service meets your needs. If you have any suggestions to help us improve our service, please give us a call. We appreciate your ideas and will respond to them.

For Your Convenience:

Please fill in the following and keep this manual with your SIXNET system for future reference:

P.O. #: _____ Date Purchased: _____

Purchased From: _____