

VT-MODEM Industrial Modems

Installation & Maintenance



Contents at a Glance:

Section 1	Overview	2
Section 2	Performance Specifications	4
Section 3	VT-MODEM Mounting	5
Section 4	Electrical Connections	6
Section 5	Modem Configuration	13
Section 6	AT Command Summary	17
Section 7	S-Register Summary	21
Section 8	Maintenance Information	23
Section 9	Product Support & Other Documents	24

Applicable standards and certifications:

ISO
9001



Total Quality

Hazardous Locations

Standard Locations

European Directives

Marine & Offshore

US Emissions

This manual applies to the following products:

General purpose industrial modem (VT-MODEM-1##)

Self-dialing industrial modem (VT-MODEM-2##)

RS485 industrial modem (VT-MODEM-3##)

Section 1 Overview

The SIXNET VT-MODEMS are rugged industrial telephone modems that have been designed for operation in electrical enclosures installed in harsh environments. All VT-MODEMS support all standard Hayes AT commands, Fax Class 1 and Class 2 commands and S-registers and therefore can be set-up as an external modem on any PC. The VT-MODEMS are compatible with any telecommunications or dial-up networking software.

A VT-MODEM allows easy access to PLCs, SIXNET I/O and other devices via dial-in telephone connections. The modem may be DIN rail or panel mounted for convenient and easy installation adjacent to other DIN rail components inside of new or existing enclosures. Most Windows software can communicate through a VT-MODEM to remote devices to perform file transfers, diagnostics, program debugging and many other operations.

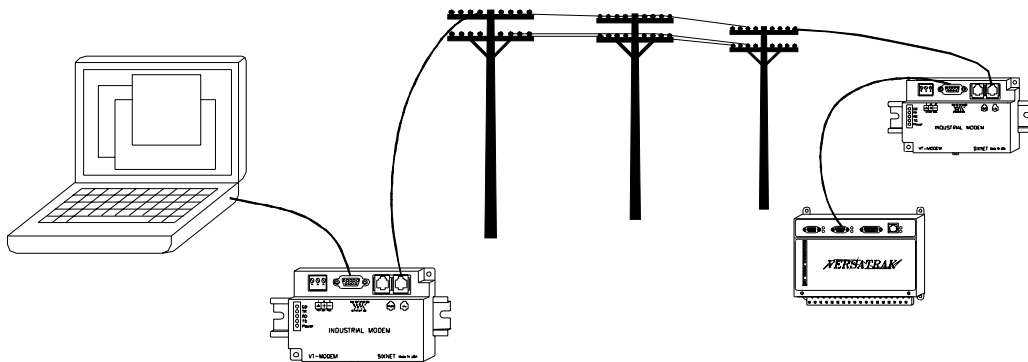

All SIXNET Industrial Modems allow communication to remote sites for data retrieval or diagnostics.

Note: All VT-MODEM models communicate over analog phone lines only.

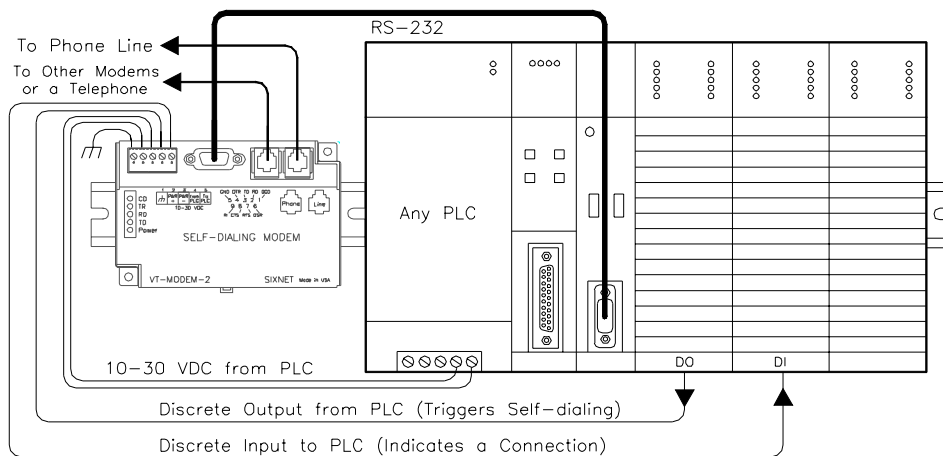

The SIXNET PLC Self-Dialing Modem (VT-MODEM-2) has all the features of the SIXNET Industrial Modem (VT-MODEM-1), plus the ability to dial out based on an alarm contact or PLC discrete output.

VT-MODEM-2 Self-Dialing Feature

The Self-Dialing Modem is triggered by a switch closure or PLC output signal. It dials a pre-stored phone number and optionally identifies itself by way of a pre-stored ASCII message. Flexible features allow this modem to perform retries or even connect to alternate number until it has verified that a connection has been established. The call will terminate when either:

- The computer completes its polling and hangs up
- The modem discrete input is turned off
- A telephone line problem disrupts the call.

The VT-MODEM-2 enables field installed equipment to establish a telephone link based upon a simple switch closure. This self-dialing modem adds “dial upon alarm” intelligence to any remote site. This enhanced modem is ideal for:

DIALING UPON ALARM FROM ANY PLC

This modem establishes a connection based upon a coil output from any PLC. Once a connection has been established, the PLC’s system (programming) port is connected to the computer at the other end of the phone link and may be polled by that computer as if the computer had initiated the call. When the modem connects to the central computer, it identifies itself so the computer can run the appropriate I/O driver and interrogate the PLC.

SENDING A MESSAGE BASED UPON A SWITCH CONTACT

Locations that do not have PLCs (or other intelligence) can originate calls to alert you to low tank levels, over temperature conditions, or other alarms. Simply connect the appropriate alarm contact to the modem’s input. The modem will dial the pre-stored phone number and deliver the ID message to the computer at the receiving end.

VT-MODEM-3 RS485 Port

The VT-MODEM-3 Industrial Modem Plus has a RS422 / RS485 port that can function in place of its RS232 port. The RS422 / RS485 port supports RS422 and RS485 full duplex, and two wire RS485 half duplex communication to compatible devices. The VT-MODEM-3 is user-configurable to communicate through either the RS232 port (VT-MODEM-1 mode) or through the RS422 / RS485 port. Only one port can be used at a time.

VT-MODEM SETUP WIZARD

A modem setup utility is provided on the SIXNET CD to help you quickly configure any SIXNET Industrial Modem. In most applications, no knowledge of modem AT commands or S register contents is necessary. Pre-configured profiles, for common situations are provided for your convenience. An extensive online help file is provided with this utility.

Section 2 Performance Specifications

Telephone Line (all models)	
Max. Data Rate	33.6 kbps (V.34)
Compatibility	V.34, V.32bis, V.32, V.22bis, V.22A/B, V.23, V.21, Bell212A & 103
Data Compression	V.42bis/MNP 5
Error Correction	V.42/MNP 2-4
Max Fax Modem Rate	14.4 kbps (V.33)
Fax Modem Compatibility	Group 3 (V.33, V.17, V.29, V.27ter, V.21 ch. 2)
Ringer Equivalent	0.3
Line Jack	RJ11
Phone Jack	RJ11 (VT-MODEM-1 and -2)
RS232 Port (all models)	
Max. RS232 Rate	115.2 kbps (Kilobaud)
RS232 Signal Support	TXD, RXD, CTS, RTS, DCD, DTR, DSR, RI, GND
RS232 Connector	DB9 female, RS232
Command Set	All standard AT and S register commands including Class 1 and Class 2 Fax commands
RS422 / RS485 Port (VT-MODEM-3 only)	
RS422 mode	4 wire full duplex
RS485 modes	2 or 4 wire party-line operation (half duplex)
Signal rate	Standard rates up to 115.2 kbps (Kilobaud)
RS422 / RS485 distance	Up to 0.5 miles
Status LEDs (all models)	
CD (Carrier detect)	The modem has detected a carrier on the phone line (a remote modem has been detected).
TR (Data Terminal Ready)	The PC (or Gateway/VersaTRAK) has established a connection to the modem and is ready.
RD (Receive Data)	Flashes as data is received from the phone line.
TD (Transmit Data)	Flashes as data is sent out the phone line.
Power	On when power is present.
General Characteristics (all models)	
Input Power	10 - 30 VDC (VT-MODEM-1, -2), 10 - 52 VDC (VT-MODEM-3)
Input Current	65mA @ 24VDC (typical)
Certification	FCC Part 15 and FCC Part 68; UL 508; CSA C22.2/14; ACA TS 001- 1997; ACA TS 002-1997; AS/NZS3260-1993; AS/NZS3548-1995; CTR21 (98/482/EC); EN55022; IEC 950:1991.
Operating Temperature	-30 ° to 70 ° C
Storage Temperature	-40 ° to 85 ° C
Humidity	5 to 95% RH (non-condensing)
Mounting	DIN rail or panel mount
Dimensions	W x 4.75L x 1.35H inches (8.2 W x 12.1 L x 3.4H cm)
PLC Discrete I/O Interface (VT-MODEM-2 only)	
Trigger Input (From PLC)	Connects to PLC output. Starts auto-dialing upon transition from OFF to ON. Modem will stay connected while input is ON.
Voltage Range	9 to 30 VDC
Input Current	6.5 mA at 24 VDC
Max. OFF Voltage	5 VDC
On-line Output (To PLC)	Output is ON as long as a connection exists (carrier detect).
Output Characteristics	Sourcing – switches supply power
Max. Output Current	100 mA

Section 3 VT-MODEM Mounting

The VT-MODEM snaps onto standard DIN rail (DIN EN 50022) or is mounted to a flat panel using #6 or #8 screws. See Figure 3-1. The modem can be installed in any orientation, directly adjacent to other DIN rail components or in any convenient location within the enclosure. The modem should be installed within 6 feet of the device it will be connected to. For SIXTRAK gateways and VersaTRAK RTUs, use the SIXNET RS232 cable (VT-CABLE-MDM), which is 6 feet in length.

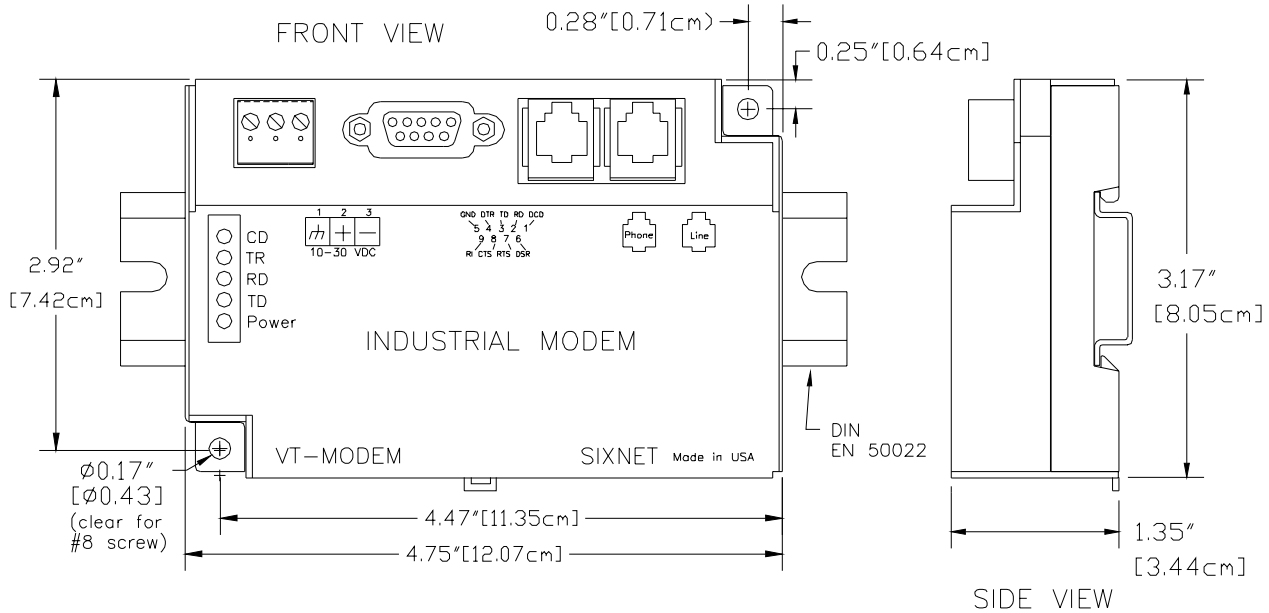

Figure 3-1: VT-MODEM DIMENSIONS, ALL MODELS

For DIN rail mounting, hook the top, rear of the modem onto the top edge of the DIN rail. Using a small flat head screwdriver, pull down on the spring-loaded tab on the bottom of the modem and push the modem back against the rail. Reverse these steps to remove the modem. See Figure 3-2 below.

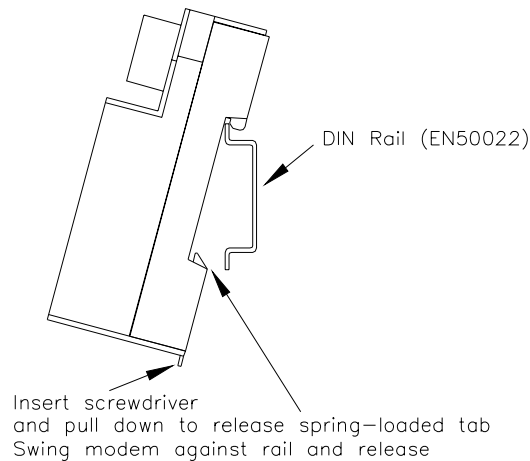

Figure 3-2: DIN RAIL MOUNTING

Section 4 Electrical Connections

RS232 Connections (All VT-MODEM Models):

Use a VT-CABLE-MDM or equivalent cable to connect the modem's RS232 port (DB9 Male cable end) to the RS232 port on a SIXTRAK Gateway, VersaTRAK RTU or PC (DB9 Female cable end). As shown in Figure 4-1, the VT-CABLE-MDM is a straight through serial communications cable suitable for connecting a DTE device (PC, Gateway or VersaTRAK) to a DCE device (VT-MODEM).

Cable requirements for PLCs and other devices may be different. Refer to the PLC or other device's documentation for cable pinouts. Some PLC cables are documented in the Technical notes provided on the SIXNET Programmable I/O for Windows CD.

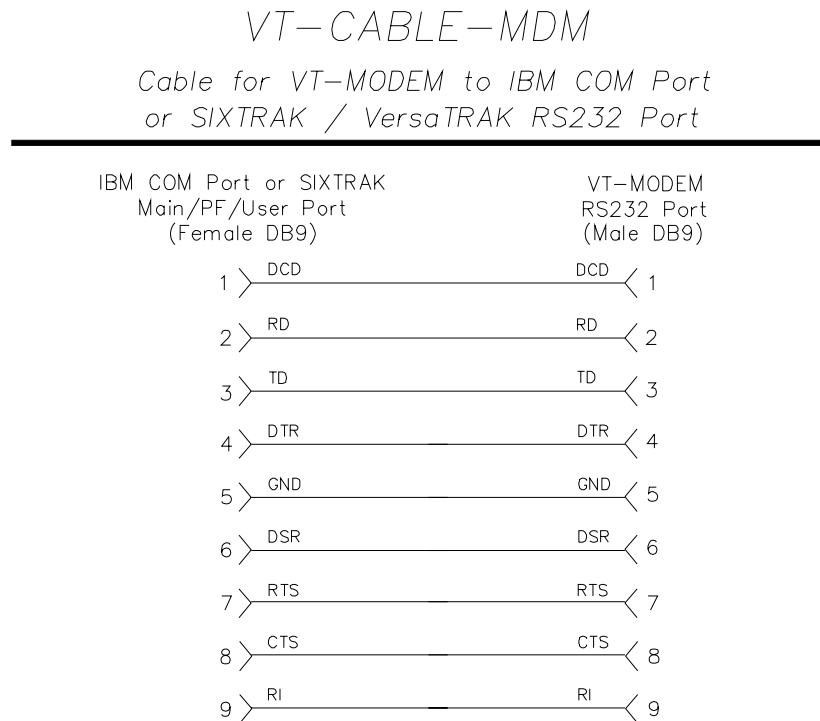

Figure 4-1: VT-CABLE-MDM Wiring

VT-MODEM-1 Power, Phone Line Connections:

DC Power Wiring

Connect 10 - 30 VDC to the VT-MODEM-1 as shown in Figure 4-2. The modem can usually be powered from the same DC source as other devices in the enclosure. All the screw terminals should be tightened to a maximum of 3.48 in-lbs.

Telephone Cable

Connect analog phone lines to the RJ-11 jacks as appropriate. One RJ-11 jack is provided to connect directly to a telephone (optional) and the second RJ-11 jack functions as the connection to the telephone network.

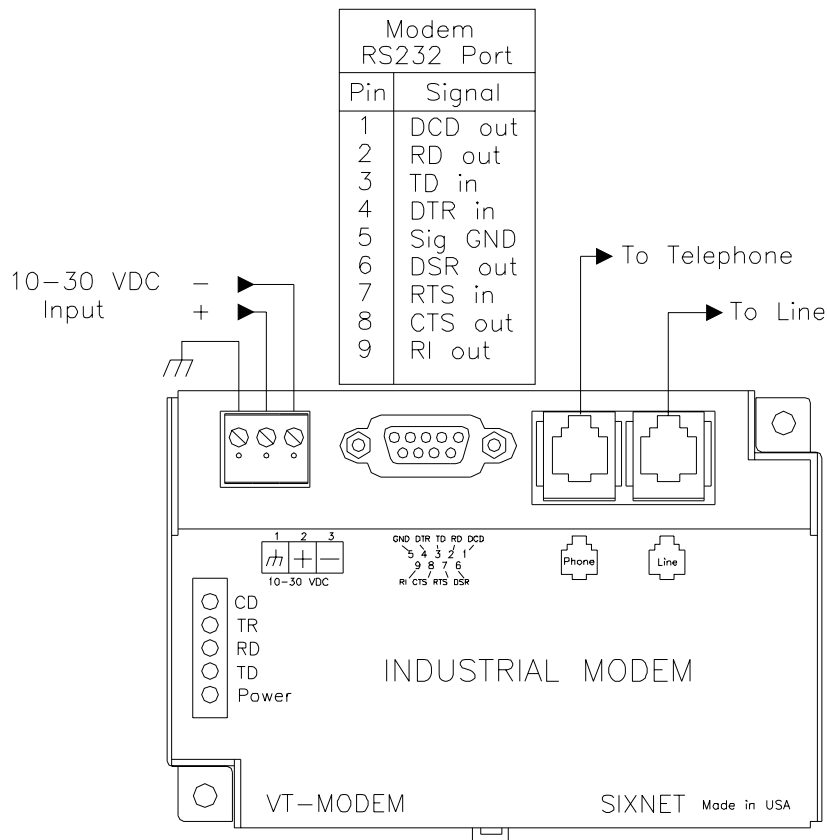

Figure 4-2: VT-MODEM-1 WIRING

VT-MODEM-2 Power, Phone Line, Self-Dial Connections:

DC Power Wiring

Connect 10 - 30 VDC to the VT-MODEM-2 as shown in Figure 4-3. The modem can usually be powered from the same source as other devices in the enclosure. All the screw terminals should be tightened to a maximum of 3.48 in-lbs.

Telephone Cable

Connect analog phone lines to the RJ11 jacks as appropriate. One RJ-11 jack is provided to connect directly to a telephone (optional) and the second RJ-11 jack functions as the connection to the telephone network.

PLC Self-Dial I/O Connections

Connect a 10-30VDC signal to the 'From PLC' (trigger input) terminal. An OFF to ON transition of this signal starts the auto-dialing sequence. The modem will call and remain connected while the signal is ON. When the signal goes false, the modem will terminate the connection or the call in progress.

The 'To PLC' (on-line output) terminal will go ON (ON = user supplied VDC input) when a modem to modem connection has been established and the proper 'Acknowledge Message' has been received.

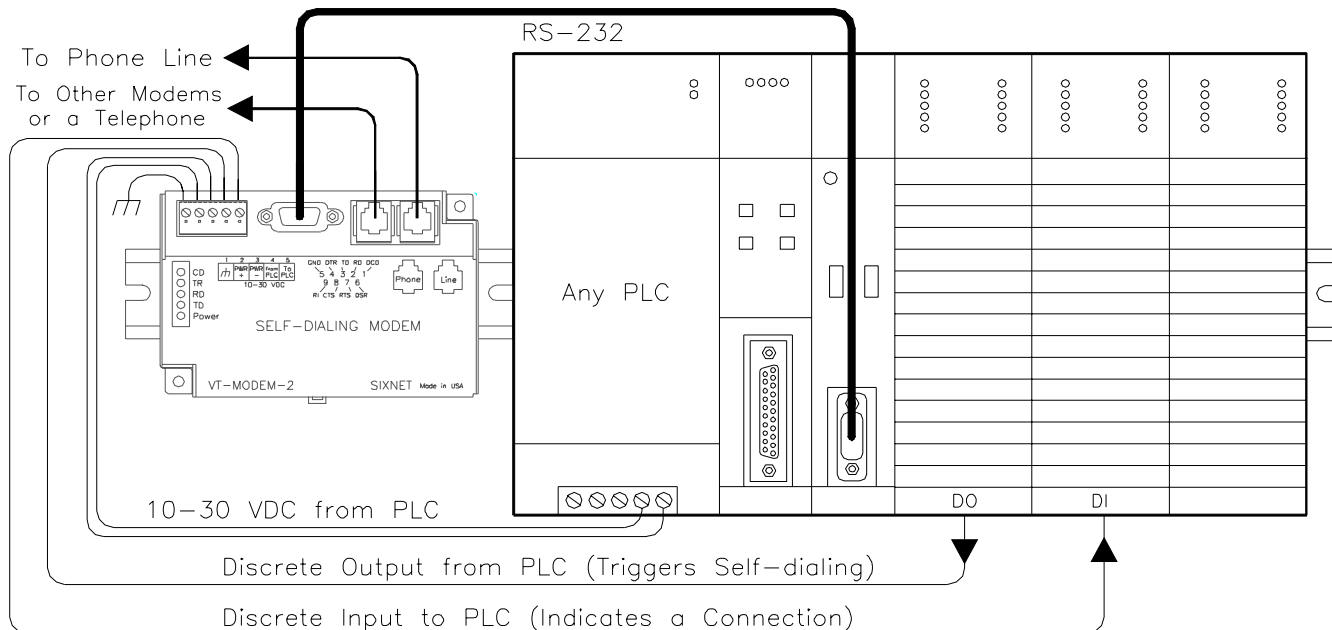

Figure 4-3: VT-MODEM-2 WIRING

VT-MODEM-3 Power, Phone Line, RS422 / RS485 Connections:

DC Power Wiring

Connect 10 - 52 VDC to the VT-MODEM-3 as shown in Figure 4-4. The modem can usually be powered from the same source as other devices in the enclosure. All the screw terminals should be tightened to a maximum of 3.48 in-lbs.

Telephone Cable

Connect an analog phone line to the RJ-11 jack as appropriate.

RS422 / RS485 Cabling and DIP Switch Settings

Refer to Figure 4-4 for typical wiring configurations. Fabricate a cable to connect the modem's RS422 / RS485 port to the field device(s).

The VT-MODEM-3 has DIP switches. These switches establish the mode of operation for the RS422/RS485 port. Set these switches to match the type of wiring connected to the RS422/RS485 port. Refer to Figure 4-5 on the next page. It is not necessary to cycle power to the modem if DIP switch changes are made.

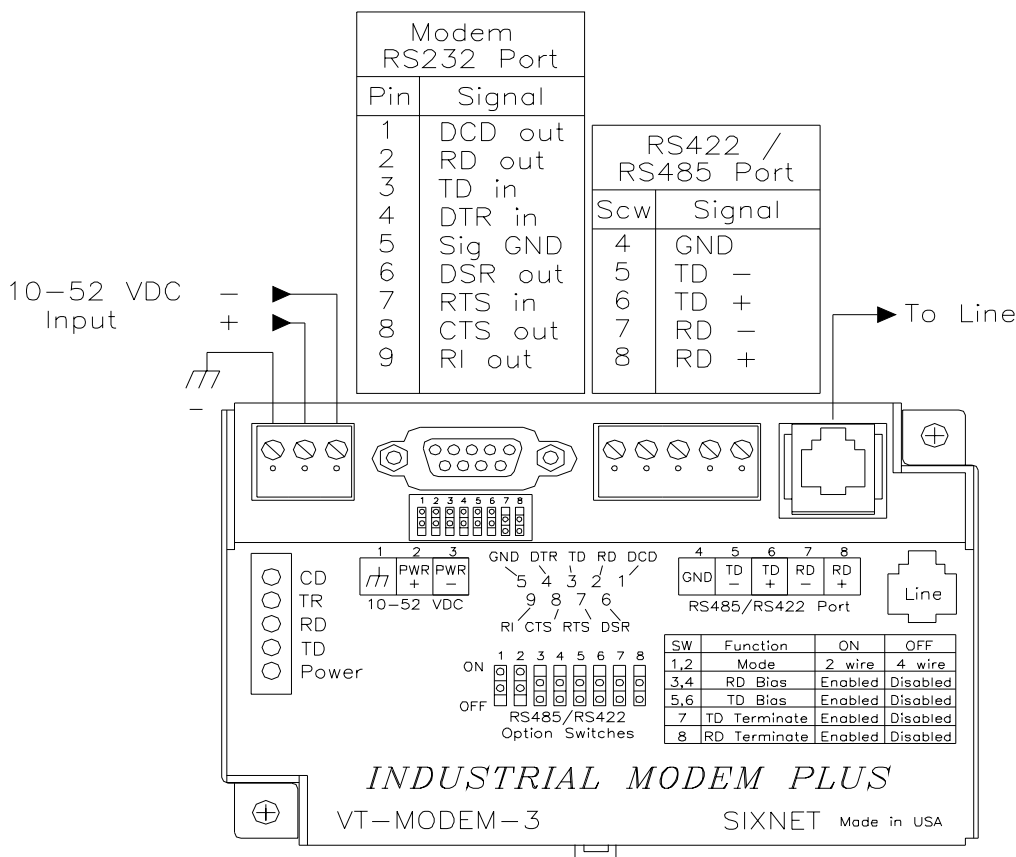

Figure 4-4: Typical RS422 / RS485 Wiring

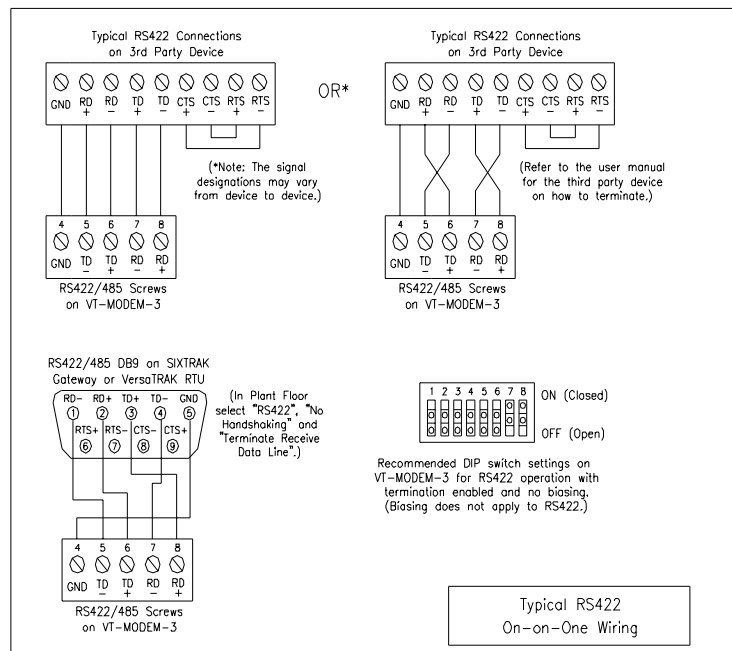
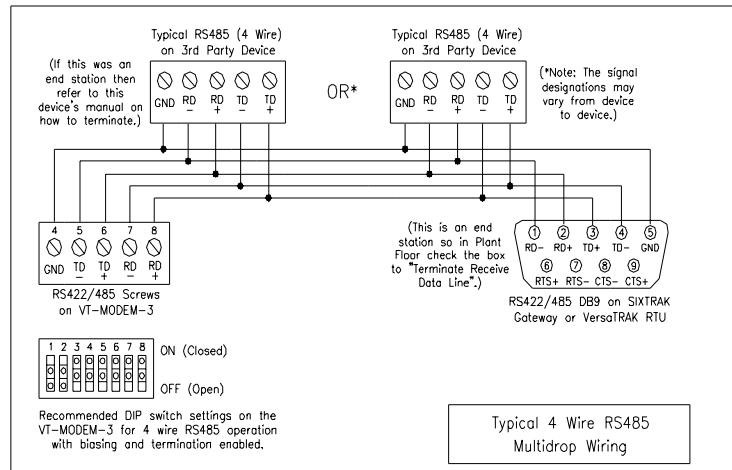
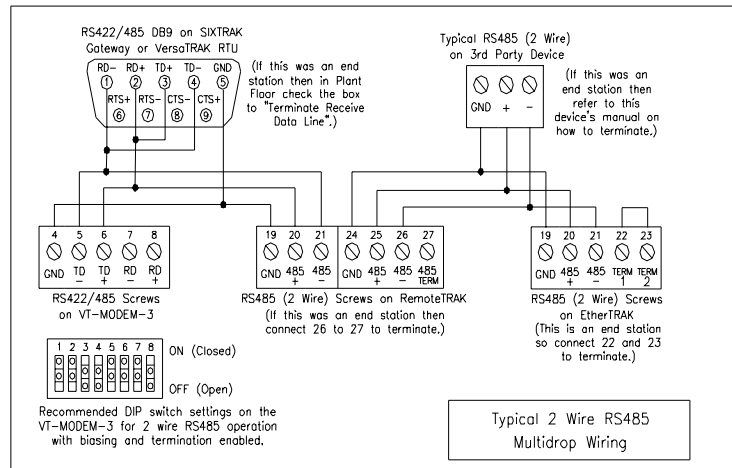
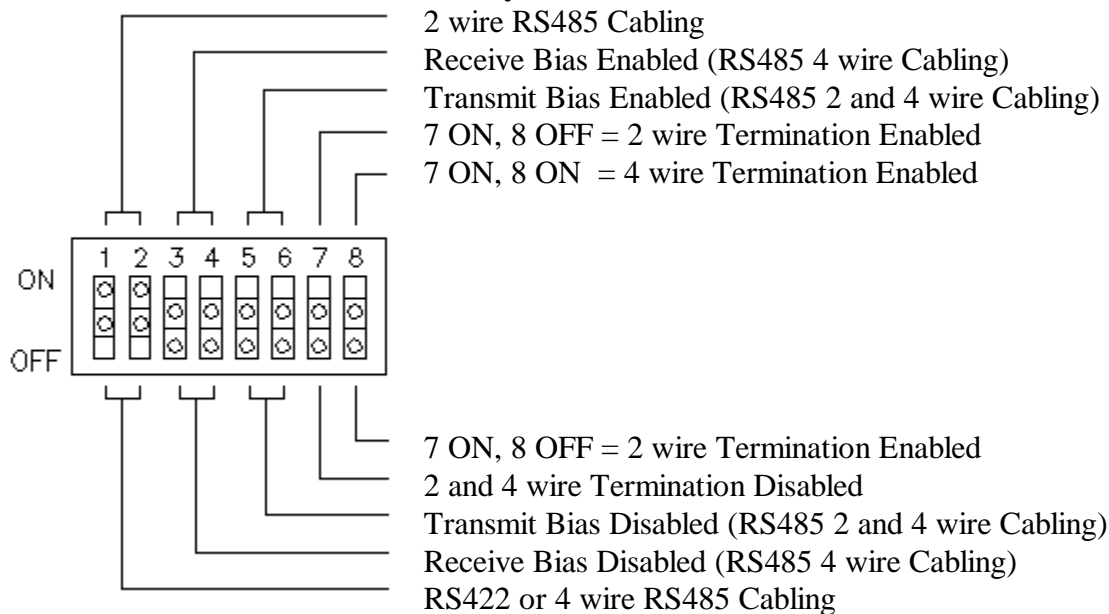

Figure 4-5: Detailed RS422 / RS485 Wiring and DIP Switch Settings

VT-MODEM-3 DIP Switch Summary



RS422 / RS485 Network Termination

The VT-MODEM-3 has built-in termination components for the Receive Data and Transmit Data signals. Termination of these signals is enabled by setting DIP switches on the VT-MODEM-3. Termination components are often built into other RS422 / RS485 devices, and are typically enabled by setting a jumper or DIP switch on the appropriate device.

Here are some guidelines for the use of termination:

- Terminations should be enabled at both ends of an RS422 communication cable.
- Terminations should be enabled at both end stations on an RS485 network. No more than two stations should be terminated on an RS485 network.

Bias Resistors (RS485 networks only)

On an RS485 two wire network there should be one pair of bias resistors acting upon the transmit/receive wires. On an RS485 four wire network there should be two pairs of bias resistors; one pair on the receive wires and one pair on the transmit wires. Bias resistors force the receive or transmit/receive wires to a known (non-floating) state when none of the RS485 devices are transmitting data. If bias resistors are not present, some RS485 devices may experience communication errors due to noise on the floating wires. Bias resistors do not apply to RS422 wiring because the wires are always driven by the two RS422 devices. The wires are not permitted to float.

The location of the bias resistors is not critical. Typically they are installed at the master RS485 device. Bias resistors are provided in the VT-MODEM-3 and are enabled through DIP switch settings. There should be only one pair of these resistors connected to an RS485 two wire network, and only two pairs of these resistors connected to an RS485 four wire network. Refer to Figure 4-5 for recommended VT-MODEM-3 DIP switch settings. Do not enable the VT-MODEM-3 bias resistors if there are bias resistors enabled on one of the other RS485 devices.

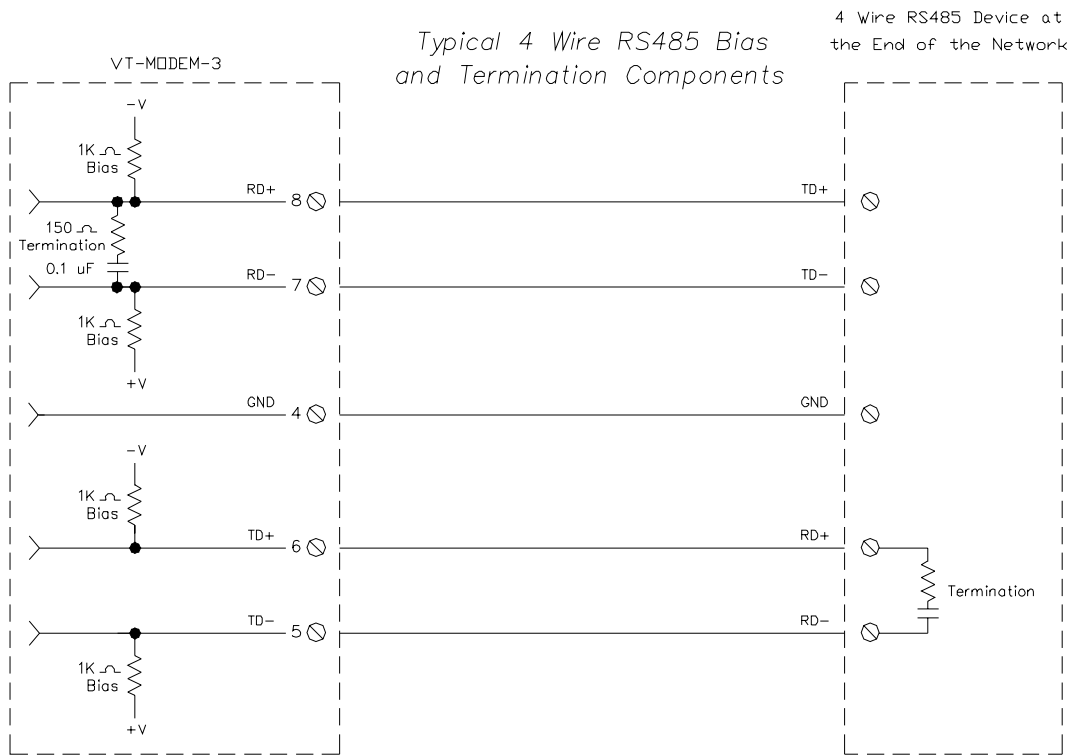
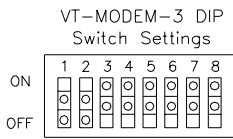
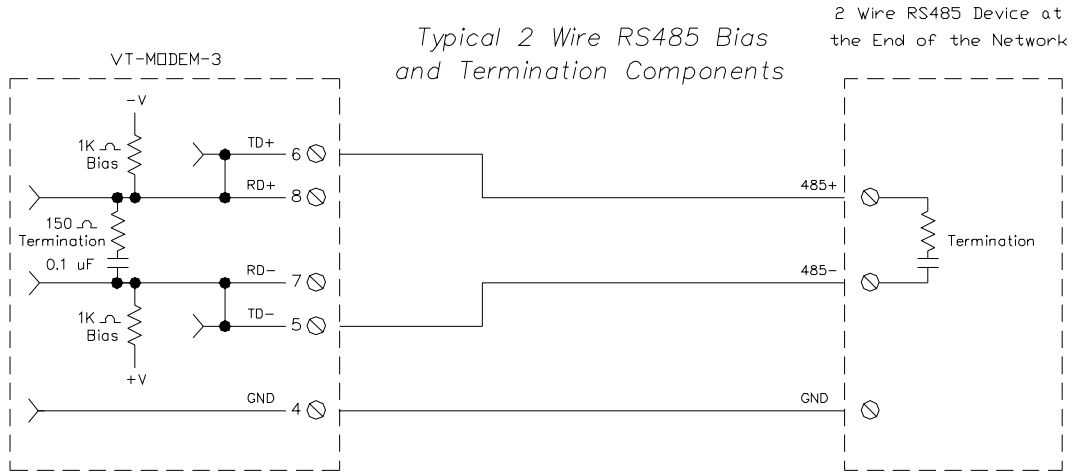
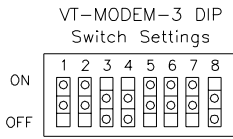

Typical RS485 Network Bias and Termination

Configuring a PC Modem to Communicate with a VT-MODEM-3 in RS422 or RS485 Mode:

It may be necessary to change your PC's modem settings when communicating with a VT-MODEM-3 running in RS422 or RS485 mode. The PC modem, VT-MODEM-3 and the modem to modem speed should all be set to the same rate.

Section 5 Modem Configuration

Configuring a VT-MODEM for use with SIXNET I/O:

All VT-MODEM models are factory configured to use the default communication settings for SIXTRAK Gateways and VersaTRAK RTUs. If a VT-MODEM is connected to a PLC, PC or other non-SIXNET device, then it may be necessary to reconfigure the modem. See the upcoming sections for further details.

AT Command String at Powerup

Upon powerup, a SIXTRAK gateway or VersaTRAK RTU can send a command string to a VT-MODEM. This capability can be used to assure that the modem is set to a particular mode of operation, such as auto answer mode. Refer to the “Set Modem String” topic in the Plant Floor program’s online help for information on this capability. Any standard AT command can be sent by the gateway or RTU.

Configuring a VT-MODEM as an External Modem on a PC:

The VT-MODEM can be connected directly to a PC. The modem will need to be “installed” in Windows prior to use. Here are instructions to install the modem in both Windows 95, 98 and Windows NT.

Modem Installation in Windows 95/98

Plug and Play method (recommended):

- 1) With the PC off, connect DC power and the telephone line to the VT-MODEM. Connect a communications cable (VT-CABLE-MDM or equivalent) between the VT-MODEM and the PC. Turn on the PC. During the boot-up process, Windows should detect the modem and display the New Hardware Found dialog box.
- 2) Make the selection “Select from a list of alternative drivers”.
- 3) The Select Device dialog will be displayed. In the column labeled Manufacturers, select “Standard Modem Types”. In the column labeled Models, select “Standard 28800 bps Modem”. Click OK. Windows will then complete the boot-up process. (The standard Windows driver is used for the VT-Modem. Although the VT-Modem supports baud rates to 33,600 bps, the selections in Windows are limited to 28800 bps.)
- 4) To verify that the modem has been installed, select Start → Settings → Control Panel, and then double click the Modems icon. The modem should be listed as “Standard 28800 bps Modem”.

Here is an alternate modem installation procedure (use if the PC is already powered up):

- 1) Connect the DC power, communications cable (VT-CABLE-MDM or equivalent) and telephone line as described above.
- 2) Select Start → Settings → Control Panel, and then double click the Modems icon.
- 3) The Install New Modem dialog box will appear. Do not select the “Don’t detect my modem, I will select it from a list”. Instead, click Next and allow Windows to search the com ports and detect the modem.
- 4) Windows should find a modem called Standard Modem. Click Next and Windows will complete installation of the Standard Modem. (Alternately, click Change and select “Standard Modem Types” from the Manufacturers list, and “Standard 28800 bps Modem” from the Models list.)

- 5) To verify that the modem has been installed, select Start → Settings → Control Panel, and then double click the Modems icon. The modem should be listed as either a “Standard Modem” or a “Standard 28800 bps Modem” depending on the steps followed above.
- 6) Upon re-booting the machine, Windows may still find the VT-MODEM as new hardware. If this happens, select “Do not install a driver (Windows will not prompt again)”.

Modem Installation in Windows NT

- 1) Select Start → Settings → Control Panel, and then double click the Modems icon.
- 2) The Install New Modem dialog box will appear. Do not select the “Don’t detect my modem, I will select it from a list”. Instead, click Next and allow Windows to search the com ports and detect the modem.
- 3) Windows should find a modem called Standard Modem. Click Next and Windows will complete installation of the Standard Modem. (Alternately, click Change and select “Standard Modem Types” from the Manufacturers list, and “Standard 28800 bps Modem” from the Models list.)
- 4) To verify that the modem has been installed, select Start → Settings → Control Panel, and then double click the Modems icon. The modem should be listed as either a “Standard Modem” or a “Standard 28800 bps Modem” depending on the steps followed above.

Once the VT-MODEM modem has been added to your Windows 95, 98 or NT system, it is ready for use.

If you are using SIXNET I/O, you can use the SIXNET Sixdial software to dial out and establish a connection with your SIXNET I/O. The Sixdial utility allows other SIXNET programs to perform operations such as data transfers, hardware configuration and diagnostics, and ISaGRAF programming. (Refer to the on-line help in the Sixdial utility for more information on these software tools).

If you are using a PLC or other device, refer to the documentation for that device as necessary.

To Remove a Modem

If it ever becomes necessary to re-install the modem for any reason, select Start → Settings → Control Panel, and then double click the System icon. Next, click the Device Manager tab. The list should display a Modems icon. Double click the Modems icon. Highlight the modem to be removed and then click the Remove button. To reinstall the modem, follow the installation steps as previously described.

Configuring a VT-MODEM Using the VT-MODEM Setup Wizard:

It is highly recommended that the SIXNET VT-MODEM Setup Wizard be used for VT-MODEM configuration. Simply check the appropriate boxes, choose the appropriate communication settings from the dropdown lists, and load the configuration into the VT-MODEM. This utility does not require user knowledge of AT commands and S-registers.

Refer to the online help system in the VT-MODEM Setup Wizard for instructions and application notes.

Note: The VT-MODEM Setup Wizard must be used to configure the self dial parameters of the VT-MODEM-2 and the RS422 / RS485 port parameters of the VT-MODEM-3.

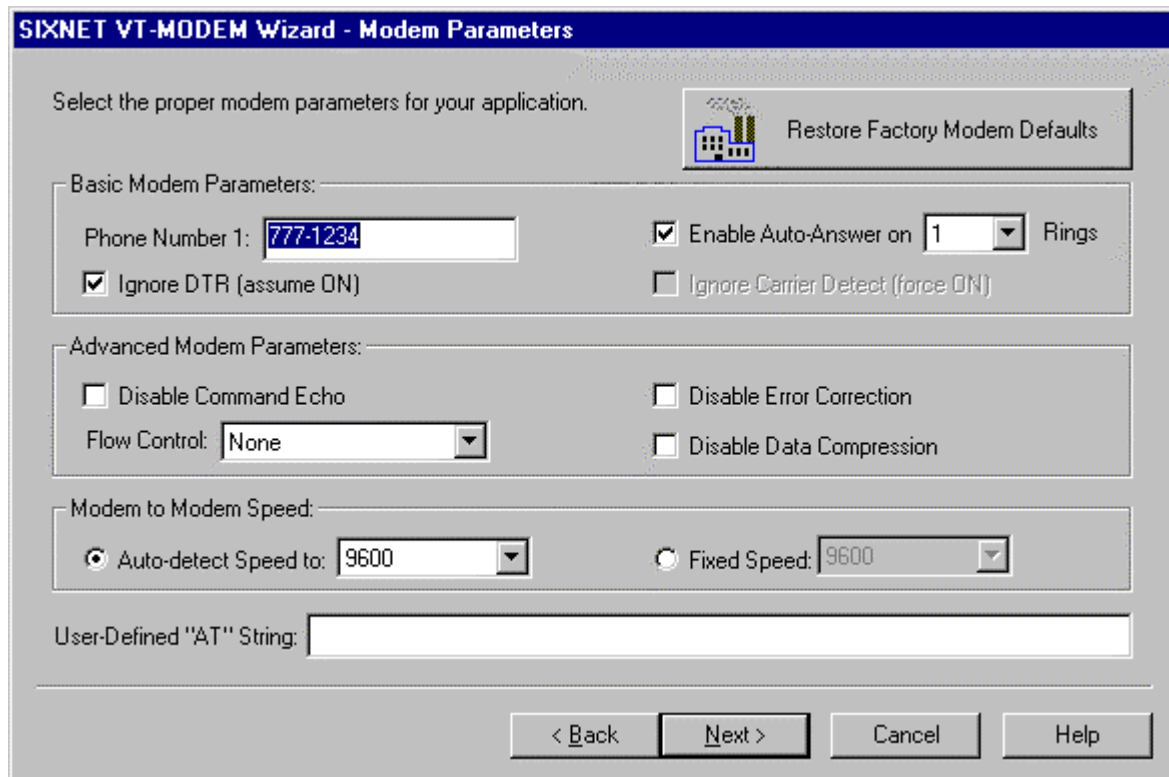

Setting the Modem's Baud Rate for the PLC

The VT-MODEM has an automatic baud rate detection feature that lets the modem recognize commands through its serial port at any supported baud rate. However, if the modem is connected to a device that does not send commands or data unless spoken to (such as most PLCs), then the modem will pass information from the phone line to its serial port at the last auto-detected baud rate. This is typically the baud rate used by the VT-MODEM setup Wizard when configuring the modem.

The VT-MODEM is defaulted at the factory for 9600-baud. To change this setting, connect the modem to a PC. Start the VT-MODEM setup Wizard and choose the baud rate that matches the PLC's baud rate. Then choose the appropriate settings and write the configuration to the modem. Exit the VT-MODEM setup Wizard and reconnect the modem to the PLC. (Be sure to cycle power to the modem.) Call the modem and verify that the PLC is responding to commands.

Limiting the Phone Line Connection Speed for Reliability

Typically, when a modem to modem connection is established, the two modems negotiate and connect at the fastest possible phone line speed that is within the capability of both modems. The quality of the phone line connection (during the negotiation) will be taken into account. If both modems are of a modern design (such as the VT-MODEM), the phone line speed can be 33.6K bits per second (or higher, using data compression). Note that this phone line speed is independent of the DTE (serial port) speed, though some older modems require that the phone line speed and DTE speed be the same.

In practice the quality of any phone line changes continually, and frequent data errors may occur. The probability of errors usually increases as the phone line speed increases. Therefore, it is often desirable to restrict the phone line speed to a rate that will provide good performance and yield reliable data. It is also commonplace to restrict the phone line speed to maintain compatibility when replacing an older modem with the VT-MODEM.

By default, the VT-MODEM will permit any phone line speed up to 115.2 kbps when data compression is enabled. If you experience intermittent or unreliable communication, try setting the modem to modem speed (in the VT MODEM Setup Wizard) to a lower value, to restrict the phone line speed. (Remember to load the new configuration to the modem.)

VT-MODEM Profile Summary

Here is a summary of the active configuration, user profile 0, user profile 1 and the factory defaults when the modem is shipped. Each time the modem is powered up, first the factory default settings (as listed in Section 6) are loaded into the active configuration. Next, the designated user stored profile is loaded into the active configuration. User profile 0 is loaded by default (see the &Y command in Section 6) and it contains all factory defaults with the exception that it is set to auto answer (register S0=1), and ignore DTR (&D0).

The User profile 1 contains all normal factory defaults (as listed in Section 6).

ACTIVE CONFIGURATION:

```
B1 E1 L1 M1 N1 Q0 T V1 W0 X4 Y0 &C1 &D0 &G0 &J0 &K3 &Q5 &R1 &S0 &T5 &X0 &Y0
S00:001 S01:000 S02:043 S03:013 S04:010 S05:008 S06:002 S07:050 S08:002 S09:006
S10:014 S11:095 S12:050 S18:000 S25:005 S26:001 S36:007 S37:000 S38:020 S44:020
S46:138 S48:007 S95:000
```

STORED PROFILE 0:

```
B1 E1 L1 M1 N1 Q0 T V1 W0 X4 Y0 &C1 &D0 &G0 &J0 &K3 &Q5 &R1 &S0 &T5 &X0
S00:001 S02:043 S06:002 S07:050 S08:002 S09:006 S10:014 S11:095 S12:050 S18:000
S36:007 S37:000 S40:104 S41:195 S46:138 S95:000
```

STORED PROFILE 1:

```
B1 E1 L1 M1 N1 Q0 T V1 W0 X4 Y0 &C1 &D2 &G0 &J0 &K3 &Q5 &R1 &S0 &T5 &X0
S00:000 S02:043 S06:002 S07:050 S08:002 S09:006 S10:014 S11:095 S12:050 S18:000
S36:007 S37:000 S40:104 S41:195 S46:138 S95:000
```

FACTORY DEFAULTS:

```
B1 E1 L1 M1 N1 Q0 T V1 W0 X4 Y0 &C1 &D2 &G0 &J0 &K3 &Q5 &R1 &S0 &T5 &X0
S00:000 S02:043 S06:002 S07:050 S08:002 S09:006 S10:014 S11:095 S12:050 S18:000
S36:007 S37:000 S40:104 S41:195 S46:138 S95:000
```

Section 6 AT Command Summary

All VT-MODEM models support the AT commands, Fax Class 1 and Class 2 commands listed in this Section. The VT-MODEM contains a set of factory default settings, which can always be restored by the user. (See the &F command.) The modem also provides two user profiles (profile 0 and profile 1) which hold settings as set and saved by the user. (See the &W command.) The settings currently in use by the modem are generally referred to as the active configuration.

Notes:

VT-MODEM-2 self-dial parameters and VT-MODEM-3 RS422 / RS485 port parameters can only be set using the VT-MODEM SETUP Wizard, which is provided on the SIXNET Programmable I/O for Windows CD. Refer to the on-line help in the VT-MODEM Setup Wizard for more information.

The following tables only list the supported AT commands. The valid parameters and default settings for each AT command are documented in the online help system of the VT-MODEM Setup Wizard.

Commands marked with an asterisk (*) have different characteristics, depending on the revision of VT-MODEM being used. Refer to the online help system of the VT-MODEM Setup Wizard for the details of these differences.

Command	Function
A/	Re-execute Last Command; do not precede by AT command and do not follow with a carriage return.
A	Go off hook and Answer A Call
AT=x	Write value x to last selected register.
AT?	Report the value of last selected register.
Bn	Set data standard to CCITT(Europe et. al.) or Bell Mode(U.S., Canada) for connections at 300 or 1200 bps.
Cn	Carrier Control (parameter = 1 only)
Dn	Dial (originate a call); typical usage: ATDT5551212 to tone dial number. ATDS=n to dial nth stored number.
E	Echo command to monitor when typed
Fn	Not available.
Hn	Disconnect (Hang up)
In	Identification; reports product code, name, ROM and firmware data, etc.
Ln	Speaker Volume (not available)
Mn	Speaker Control (not available)
* Nn	Automode Enable; enabled allows connection at highest possible modem speed, disabled fixes speed according to register S37.
On	Return To On-line Data Mode
P	Set Pulse Dial Default.
Qn	Quiet Results Codes Control; when enabled, result codes are reported to the monitor.
Sn	Establishes S Register n as the last register accessed
Sn-x	Write value x to S Register n.
Sn?	Reports the value of S Register n.
T	Set Tone Dial Default
Vn	Set Result Code Format to terse or verbose.

Wn	Connect Message Control sets the format of the connect messages.
Xn	Extended results code
Yn	Long space disconnect
Zn	Perform Soft Reset and Restore stored user configuration profile 0 or 1.
&Cn	RLSD (DCD) Option; set DCD signal to indicate presence of carrier or forces DCD signal on at all times.
&Dn	DTR Option; set how modem interprets the DTR signal.
&Fn	Restore factory configuration profile 0 or 1.
&Gn	Select guard tone
&Jn	Telephone jack control
&Kn	Set Flow Control
* &Mn	Asynchronous/synchronous mode selection
&Pn	Select pulse dial make/break ratio
* &Qn	Asynchronous/synchronous mode selection
&Rn	RTS/CTS option sets how the modem controls the CTS signal
&Sn	DSR Override sets how the modem controls the DSR signal
&Tn	Test & diagnostic settings
&V	Display current configuration, stored user profiles and stored telephone numbers
&V1	Display last connection statistics
&Wn	Store current active configuration in one of the two user profiles
&Xn	Select synchronous clock source
&Yn	Designate a default-reset profile. This profile will be active after a hard reset
&Zn=x	Store phone number; n = 0 to 3 and x = dial string
%E	Enable/disable line quality monitor and autoretrain or fallback/fail forward
%L	Report line signal level
%Q	Report line signal quality
%7	Plug and Play Serial Number
%8	Plug & Play Vendor ID, Prod. No.
\Kn	Break Control sets how the modem responds to a break signal
\Nn	Sets the Operating Mode of the modem: direct, normal, reliable or auto reliable
\Vn	Single Line Connect Message Enable
* +MS	Select Modulation allows control of the modulation the modem uses to negotiate a connection
+Hn	Enable/Disable RPI and DTE Speed
* -SDR	Enable/disable distinctive ring
**	Download to flash memory
%Cn	Enable/Disable Data Compression (MNP5, V42bis or both)
\An	Select Max MNP Block Size
\Bn	Transmit Break to Remote sets the length of break signal sent to remote modem(in non error correction mode)

)Mn	Enable Cellular Power Level Adjust (only included for compatibility and performs no function)
*Hn	Link Negotiation Speed (only included for compatibility and performs no function)
-Kn	MNP Extended Services
-Qn	Enable Fallback to V.22bis/V.22 (only included for compatibility and performs no function)
-SEC=n	Enable/Disable MNP10-EC
@Mn	Initial Cellular Power Level Setting (only included for compatibility and performs no function)
:E	Compromise Equalizer Enable (only included for compatibility and performs no function)
*B	Display Blacklisted Numbers
*D	Display Delayed Numbers
* *NCn	Country Select
FAX CLASS 1:	
+FCLASS=n	Service Class
+FAE=n	Data/Fax Auto Answer
+FRH=n	Receive Data with HDLC Framing
+FRM=n	Receive Data
+FRS=n	Receive Silence
+FTH=n	Transmit Data with HDLC Framing
+FTM=n	Transmit Data
+FTS=n	Stop Transmission and Wait
FAX CLASS 2:	
+FCLASS=n	Service Class
+FAA=n	Adaptive Answer
+FAXERR	Fax Error Value
+FBOR	Phase C Data Bit Order
+FBUF?	Buffer Size (Read Only)
+FCFR	Indicate Confirmation to Receive
+FCON	Facsimile Connection Response
+FCIG	Set the Polled Station Identification
+FCIG:	Report the Polled Station Identification
+FCR	Capability to Receive
+FCSI:	Report the Called Station ID
+FDCC=	DCE Capabilities Parameters
+FDCS:	Report Current Session
+FDCS=	Current Session Results
+FDIS:	Report Remote Capabilities
+FDIS=	Current Session Parameters

+FDR	Begin or Continue Phase C Receive Data
+FDT=	Data Transmission
+FDTC:	Report the Polled Station Capabilities
+FET:	Post Page Message Response
+FET=n	Transmit Page Punctuation
+FHNG	Call Termination with Status
+FK	Session Termination
+FLID=	Local ID String
+FLPL	Indicate a Document for Polling
+FMDL?	Identify Model
+FMFR?	Identify Manufacturer
+FPHCTO	Phase C Time Out
+FPOLL	Indicates Polling Request
+FPTS:	Page Transfer Status
+FREV?	Identify Revision
+FSPL	Enable Polling
+FTSI:	Report the Transmit Station ID
* Caller ID:	
* #CID=0	Disable Caller ID
* #CID=1	Enable Caller ID with Formatted Presentation
* #CID=2	Enable Caller ID with Unformatted Presentation
AudioSpan and DSVD:	
-SMS=	Select AudioSpan/DSVD Mode
-SSE=	Enable/Disable DSVD
-SQS=	Select AudioSpan Modulation
Synchronous Access Mode:	
* +ES	Enable/Disable Synchronous Access Mode in the client or central site modem
+ESA	Configures the Operation of the Synchronous Access Submode
+ITF	Selects Transmit Flow Control Thresholds

Section 7 S Register Summary

Note:

The following tables only summarize the supported S-registers. A description for each S-register may be found in the online help system of the VT-MODEM Setup Wizard.

Register	Function	Range	Units	Default
S0	Number of rings required before modem auto answers	0-255	rings	0
S1	Ring counter increments each time a ring is detected	0-255	rings	0
S2	Escape character	0-255	ASCII	43
S3	Carriage return character	0-127	ASCII	13
S4	Line feed character	0-127	ASCII	10
S5	Backspace character	0-255	ASCII	8
S6	Maximum time to wait after going off-hook to dial when blind dialing	2-255	sec	2
S7	Maximum time to wait for carrier after dialing before hanging up	1-255	sec	50
S8	Pause time for dial delay modifier	0-255	sec	2
S9	Carrier detect response time; duration that carrier must be present for modem to consider it a valid connection	1-255	0.1s	6
S10	Carrier loss disconnect time; carrier must be absent for this time for modem to consider it a lost connection	1-255	0.1s	14
S11	DTMF tone duration	50-255	0.001s	95
S12	Escape prompt delay; this delay must be present after receipt of the last character of the escape sequence(before receipt of any other character) for the escape sequence to be recognized	0-255	0.02s	50
S13	Reserved	-	-	-
S14	General bit mapped options indicates the status of the following options: echo, quiet mode, results codes, tone/pulse and originate/answer	-	-	138(8Ah)
S15	Reserved	-	-	-
S16	Test mode bit mapped options (&T)	-	-	0
S17	Reserved	-	-	-
S18	Test timer –length of test initiated by &Tn command	0-255	s	0
S19	AutoSync Bit Mapped Options	-	-	0
S20	AutoSync HDLC Addr or BSC Sync Char	0-255	-	0
S21	V24/general bit mapped options indicates the status of the following options: CTS(&Rn), DTR(&Dn), DCD(&Cn), DSR(&Sn), long space disconnect(Yn)	-	-	52(34h)
S22	Speaker/results bit mapped options indicates the status of the following options: speaker control(Ln), volume(Mn), results codes(Xn)	-	-	117(75h)
S23	General Bit Mapped Options	-	-	58(3Ah)

S24	Sleep inactivity timer sets the length of time that the modem will operate in normal mode without activity on the phone or RS232 port before entering sleep mode	0-255	s	0
S25	Delay to DTR (CT108) off sets time modem ignores DTR signal before taking action specified by &Dn	0-255	s/0.01s	5
S26	RTS-to-CTS (CT105 to CT106) delay if &R0 is set	0-255	0.01s	1
S27	General Bit Mapped Options for sync/async control(&Mn/&Qn), leased line control(&Ln), clock select(&Xn), Bell/CCITT mode(Bn)	-	-	73(49h)
S28	General Bit Mapped Options indicates options for pulse dialing(&Pn), MNP Link negotiation speed(*Hn)	-	-	0
S29	Flash Modifier Time sets the length of time the modem will go on hook if the flash dial modifier(!) is encountered in the dial string	0-255	10 ms	70
S30	Inactivity timer sets the length of time the modem will remain on line if no data is sent or received	0-255	10s	0
S31	General Bit Mapped Options	-	-	194(C2h)
S32	XON character	0-255	ASCII	17(11h)
S33	XOFF character	0-255	ASCII	19(13h)
S34-S35	Reserved	-	-	-
S36	LAPM Failure Control used when register S48=128	-	-	7
* S37	Desired Line Connection Speed (when N1 is set)	-	-	0
S38	Delay before forced hang-up (time delay between the receipt of H command to disconnect and the actual disconnect operation)	0-255	s	20
S39	Flow control bit mapped options	-	-	3
S40	General bit mapped options	-	-	104(68h)
S41	General bit mapped options	-	-	195(C3h)
S42-S45	Reserved	-	-	-
S46	Enable/Disable Data Compression	-	-	138
S48	V.42 Negotiation Control	-	-	7
S82	LAPM Break Control	-	-	128(40h)
S86	Call Failure Reason Code; when the No Carrier result code is issued, the reason for the failure is written to this register	0-255	-	-
S91	PSTN transmit attenuation level	0-15	dBm	10
S92	Fax transmit attenuation level	0-15	dBm	10
S95	Result code messages control	-	-	0

Section 8 Maintenance Information

Troubleshooting Tips

VT-MODEM Default LED Indications

All VT-MODEM models have the following LEDs.

LED	Default Indication
Carrier Detect	This LED will come ON once a phone line connection has been established, and will remain on for as long as the connection is maintained.
Data Terminal Ready	This LED should be ON at all times.
Receive Data	This LED will come ON whenever characters are received through the phone line.
Transmit Data	This LED will come ON whenever the modem sends characters out the phone line.
Power LED	Normal Indication (All models): This LED will be ON when power is applied to the modem. Additional States (VT-MODEM-2 only): A “Slow” blink indicates an invalid configuration or that the “Block COM Port Until Connected” feature is enabled. A “Fast” blink indicates that a self-dial is in process or that the modem is in “Configure Self-dialing Parameters” mode.

Note: The RD and TD LEDs indicate the flow of characters in and out of the phone line interface of the VT-MODEM, and are not directly connected to the RS232 port (all models) or RS422 / RS485 port (VT-MODEM-3).

Reconnecting Serial Cables

It is important to cycle (remove and then reapply) DC power to a VT-MODEM each time the RS232 or RS422 / RS485 cable is disconnected and then reconnected. The serial port of the modem may not function properly if power is not cycled.

Resetting the VT-MODEM (all models)

If it ever becomes necessary to completely reset the modem including both user profiles to the basic factory default settings, the following command can be issued:

```
AT&F&W&W1 [CR]
```

This command string will load the factory defaults into the active configuration (&F) and then save those settings into both user profile 0 (&W) and user profile 1 (&W1).

Note that after the modem is reset completely to the factory defaults, it will no longer be set to auto-answer, which is often necessary for the modem to work when connected to a remote device. Use the VT-MODEM Setup Wizard to adjust these settings appropriately.

Section 9 Product Support and Additional Documents

To obtain support for SIXNET products, call SIXNET and ask for applications engineering.

Our phone numbers are:

+1 (518) 877-5173 Office
+1 (518) 877-8346 Fax
e-mail: support@sixnetio.com

Our mailing address:

SIXNET
Northway Ten Professional Park
P.O. Box 767
Ushers Rd.
Clifton Park, NY 12065

Visit our web page at: <http://www.sixnetio.com>

BUYER PROTECTION PLAN

SIXNET protects your investment in SIXNET industrial modems with this unique Buyer Protection Plan.

SIXNET provides a liberal 18 month from time of purchase limited warranty (see below) on SIXNET industrial modems. We also offer an extended 36-month warranty option for users with long-term requirements.

SIXNET promises to continue to maintain each model of industrial modem we offer for sale for a minimum of five years, so you can design your system only once and be assured of continued supply and high-quality after-sale service. We further promise to plan each product improvement and new feature to be upward compatible with existing designs and installations. Our goal is to make each new product release better than the one it replaces by providing new features, increased reliability and performance, and continued support for existing features.

SIXNET protects your investment even further with a liberal five-year trade-in policy. You may exchange standard SIXNET products for upgraded versions of the same or upward compatible products to take advantage of new features and performance improvements at any time for five years. A liberal prorated exchange allowance will be given for your existing equipment. You may contact SIXNET directly to trade-up on any industrial modem product.

SIXNET INDUSTRIAL MODEM EXCHANGE ALLOWANCE

Time Since the

<u>Original Purchase</u>	<u>Trade-In Allowance</u>
0 to 1 Year	50%
1 to 2 Years	40%
2 to 3 Years	30%
3 to 4 Years	20%
Over 4 Years	10%

SIXNET Statement of Limited Warranty

Digitronics SIXNET (^SIXNET'), manufacturer of SIXNET Industrial Modems, warrants to Buyer that products, except software, manufactured by SIXNET will be free from defects in material and workmanship. SIXNET' obligation under this warranty will be limited to repairing or replacing, at SIXNET' option, the defective parts within one year of the date of installation, or within 18 months of the date of shipment from the point of manufacture, whichever is sooner. Products may be returned by Buyer only after permission has been obtained from SIXNET. Buyer will prepay all freight charges to return any products to the repair facility designated by SIXNET.

SIXNET further warrants that any software supplied as part of a product sale, except obsolete products, will be free from non-conformances with SIXNET published specifications for a period of 90 days from the time of delivery. While SIXNET endeavors to improve the features and performance of software associated with its products, no effort on the part of SIXNET to investigate, improve or modify SIXNET software at the request of a customer will obligate SIXNET in any way.

This limited warranty does not cover losses or damages which occur in shipment to or from Buyer or due to improper installation, maintenance, misuse, neglect or any cause other than ordinary commercial or industrial applications. In particular, SIXNET makes no warranties whatsoever with respect to implied warranties of merchantability or fitness for any particular purpose. All such warranties are hereby expressly disclaimed. No oral or written information or advice given by SIXNET or SIXNET's representative shall create a warranty or in any way increase the scope of this warranty. This limited warranty is in lieu of all other warranties whether oral or written, expressed or implied. SIXNET's liability shall not exceed the price of the individual units, which are the basis of the claim. In no event shall SIXNET be liable for any loss of profits, loss of use of facilities or equipment, or other indirect, incidental or consequential damages.

These products must not be used to replace proper safety interlocking. No software based device (or other solid state device) should ever be designed to be responsible for the maintenance of consequential equipment or personnel safety. In particular, SIXNET disclaims any responsibility for damages, either direct or consequential, that result from the use of this equipment in any application.

Service Information

We sincerely hope that you never experience a problem with any **SIXNET** product. If you do need service, call **SIXNET** at (518) 877-5173 and ask for Applications Engineering. A trained specialist will help you to quickly determine the source of the problem. Many problems are easily resolved with a single phone call. If it is necessary to return a unit to us, an RMA (Return Material Authorization) number will be given to you.

SIXNET tracks the flow of returned material with our RMA system to ensure speedy service. You must include this RMA number on the outside of the box so that your return can be processed immediately.

The applications engineer you are speaking with will fill out an RMA request for you. If the unit has a serial number, we will not need detailed financial information. Otherwise, be sure to have your original purchase order number and date purchased available.

We suggest that you give us a repair purchase order number in case the repair is not covered under our warranty. You will not be billed if the repair is covered under warranty.

Please supply us with as many details about the problem as you can. The information you supply will be written on the RMA form and supplied to the repair department before your unit arrives. This helps us to provide you with the best service, in the fastest manner. Normally, repairs are completed in two days. Sometimes difficult problems take a little longer to solve.

If you need a quicker turnaround, ship the unit to us by airfreight. We give priority service to equipment that arrives by overnight delivery. Many repairs received by mid-morning (typical overnight delivery) can be finished the same day and returned immediately.

SIXNET pays the return freight for material repaired under warranty. The method of outgoing shipment will be equivalent to the way you shipped the unit to us. If you send the unit by air, we will return it by air.

We apologize for any inconvenience that the need for repair may cause you. We hope that our rapid service meets your needs. If you have any suggestions to help us improve our service, please give us a call. We appreciate your ideas and will respond to them.

For Your Convenience:

Please fill in the following and keep this manual with your **SIXNET** system for future reference:

P.O. #: _____ Date Purchased: _____

Purchased From: _____

Additional Documents

The **SIXNET Programmable I/O for Windows** CD has the following documents, which provide additional information pertaining to the VT-MODEM and its usage:

VT-MODEM Help File This online help system is accessed on the CD by selecting **Manuals and Documents → User Manuals → Modem Help File**

The following Technical Notes, in addition to others, are accessible on the CD by **selecting Manuals and Documents → Technical Notes**. The VT-MODEM Wizard configurations (*.6ms), mentioned in these Technical notes, are provided in the \sixtrak directory of the CD.

- TN 601** **VT-MODEM Interfaces to Allen-Bradley PLC**
This document describes interfacing a VT-MODEM to an Allen-Bradley 500 series PLC. AB500.6ms - pre-configured VT-MODEM Wizard configuration contains typically required modem settings, refer to the technical note #601 for further details.
- TN 606** **VT-MODEM Replaces an Existing 1200, 2400, or 9600-Baud Modem**
This document describes the settings necessary to configure the VT-MODEM to functionally replace an existing 1200, 2400 or 9600-baud modem.
- TN 607** **VT-MODEM Connects GE PLC to Your Personal Computer**
This document describes interfacing a VT-MODEM to a GE 90-30 PLC. GE9030.6ms - pre-configured VT-MODEM Wizard configuration contains typically required modem settings, refer to the technical note #607 for further details.
- TN 610** **VT-MODEM Connects to Allen-Bradley PLC-5**
This document describes interfacing a VT-MODEM to an Allen-Bradley PLC-5. ABPLC5.6ms - pre-configured VT-MODEM Wizard configuration contains typically required modem settings, refer to the technical note #610 for further details.
- TN 614** **VT-MODEM Connects to PLC Direct DL250 PLC**
This document describes interfacing a VT-MODEM to a *PLC Direct* DL 250 PLC. PLC250.6ms - pre-configured VT-MODEM Wizard configuration contains typically required modem settings, refer to the technical note #614 for further details.

FCC Requirements for Consumer Products

The Federal Communications Commission (FCC) has established rules which permit this device to be directly connected to the telephone network. Standardized jacks are used for these connections. This equipment should not be used on party lines or coin lines.

If this device is malfunctioning, it may also be causing harm to the telephone network; this device should be disconnected until the source of the problem can be determined and until repair has been made. If this is not done, the telephone company may temporarily disconnect service.

The telephone company may make changes in its technical operations and procedures; if such changes affect the compatibility or use of this device, the telephone company is required to give adequate notice of the changes.

If the telephone company requests information on what equipment is connected to their lines, inform them of:

- A) The telephone number that it is connected to,
- B) The Ringer Equivalence Number 0.3
- C) The USOC jack required RJ11, and
- D) The FCC Registration Number 34579-MD-E

Items (b) and (d) are indicated on the label. The ringer equivalence number (REN) is used to determine how many devices can be connected to your telephone line. In most areas, the sum of the RENs of all devices on any one line should not exceed five (5.0). If too many devices are attached, they may not ring properly.

In the event of equipment malfunction, all repairs should be performed by our Company or authorized agent. It is the responsibility of users requiring service to report the need for service to our company or one of our authorized agents.

SIXNET
Northway Ten Professional Park
PO Box 767
Ushers Road
Clifton Park, NY 12065
518-877-5173

Industry Canada Requirements

The VT-MODEM meets the procedural and specification requirements for certification under the Terminal Attachment Program.

CERTIFICATION NO.:	2991 8926 A
ISSUED TO:	SIXNET
TYPE OF EQUIPMENT:	MULTI-MEDIA DEVICE
TRADE NAME AND MODEL:	VT-MODEM-1, VT-MODEM-2, VT-MODEM-3
METHOD OF CONNECTION:	CA11A
RINGER EQUIVALENCE NO.:	0.3
CERTIFIED TO:	SPECIFICATION CS03 ISSUE 8
NETWORK INTERFACE:	LS

Regulatory Notices

Any European Country:

The VT-MODEM-1 (-2 and -3) EC are in conformity with relevant regulatory standards following the provisions of European Council Directives: 73/23/EEC (Low Voltage Directive) and 89/336/EEC amended by 92/31/EEC (EMC Directive).

The VT-MODEM-1- (-2 and -3) EC have been approved in accordance with Council Decision 98/482/EC for pan-European single terminal connection to the public switched telephone network (PSTN). However, due to differences between the individual PSTNs provided in different countries, the approval does not, of itself, give an unconditional assurance of successful operation on every PSTN network termination point. In the event of problems, you should contact SIXNET in the first instance.

Australia:

The VT-MODEM-1 (-2 and -3) EC shall be connected to the Telecommunication Network through a line cord, which meets the requirements of Australian Communications Authority (ACA) Technical Standard TS008. An Australian Approved Power Supply or AC Adapter shall be utilized with the product.

AS/NZS3548:1995-

WARNING: This is a Class A product. In a domestic environment, this product may cause radio interference, in which case the user may be required to take adequate action.

Germany:

Diese VT-MODEM-1(-2 and -3) EC als Endeinrichtung vorgesehen und muss an ein TAE mit F-Kodierung angeschlossen werden.

(This VT-MODEM-1(-2 and -3) EC is a terminal equipment, which must be connected to the PSTN using an F-coded connector/plug.)

IEC950:1991-

The Industrial Modem shall be connected to Telecommunications Network through a line cord approved by the necessary authorities of the country. The Industrial Modem shall be utilized with a power supply approved by the necessary authorities of the country.

United Kingdom:

The VT-MODEM is intended for direct connection to the analogue Public Switched Telecommunications Network and is approved for use within the United Kingdom with following features:

- Modem facility
- Autocalling facility
- Autoanswering facility
- DTMF signaling

CAUTION: The analogue telecommunications interface of the VT-MODEM is intended to be connected to Telecommunication Network Voltage (TNV) circuits, which may carry dangerous voltages. If it is subsequently desired to open the host equipment for any reason, the telephone cord must be disconnected prior to effecting access to any internal parts, which may carry telecommunication network voltages.

Service can be facilitated through our office at:

SIXNET
Northway Ten Professional Park
PO Box 767
Ushers Road
Clifton Park, NY 12065 USA
518-877-5173