

EK Series

**Industrial Ethernet
Rack Mount Switches**



Hardware Guide

Contents at a Glance:

Section 1	General Information	Page 3
Section 2	Installation and Mounting	Page 6
Section 3	Thermal Considerations	Page 10
Section 4	Power Wiring	Page 12
Section 5	Communication Wiring	Page 15
Section 6	LED Indicators	Page 19
Section 7	Reset Button	Page 22
Section 8	Technical Specifications	Page 23
Section 9	Service Information	Page 25

This manual applies to the following products:

- **EK26...** 26-port managed industrial Ethernet rack mount switch with 8 Gigabit ports
- **EK32...** 32-port managed industrial Ethernet rack mount switch with 6 Gigabit ports
- **EF26...** 26-port managed industrial Ethernet rack mount switch with 0 Gigabit ports
- **EF32...** 32-port managed industrial Ethernet rack mount switch with 0 Gigabit ports

SIXNET Protected Technology Policy - SIXNET protects your investment in SIXNET systems with long-term planned technology and our unique Protected Technology Policy. We will continue to support the specified capabilities of standard SIXNET products for at least five years (twenty years for Industrial Managed Switches). We plan each product improvement and new feature to be upward compatible with existing designs and installations. Our goals are to make each new software release bring new power to your SIXNET systems and have every existing feature, applications program and data file continue to work. We protect your investment even further with a liberal five-year trade-in policy. Exchange standard products for upgraded versions of the same product to take advantage of new features and improvements at any time for five years. A prorated trade-in allowance will be given for your existing unit. SIXNET protects your long-term productivity with state-of-the-art planned technology and continued support.

SIXNET Statement of Limited Warranty - SIXNET, manufacturer of SIXNET products, warrants to Buyer that products, except software, manufactured by SIXNET will be free from defects in material and workmanship. SIXNET's obligation under this warranty will be limited to repairing or replacing, at SIXNET's option, the defective parts within one year of the date of installation, or within 18 months of the date of shipment from the point of manufacture, whichever is sooner. Products may be returned by Buyer only after permission has been obtained from SIXNET. Buyer will prepay all freight charges to return any products to the repair facility designated by SIXNET. This limited warranty does not cover losses or damages which occur in shipment to or from Buyer or due to improper installation, maintenance, misuse, neglect or any cause other than ordinary commercial or industrial applications. In particular, SIXNET makes no warranties whatsoever with respect to implied warranties of merchantability or fitness for any particular purpose. All such warranties are hereby expressly disclaimed. No oral or written information or advice given by SIXNET or SIXNET's representative shall create a warranty or in any way increase the scope of this warranty. This limited warranty is in lieu of all other warranties whether oral or written, expressed or implied. SIXNET's liability shall not exceed the price of the individual units, which are the basis of the claim. In no event shall SIXNET be liable for any loss of profits, loss of use of facilities or equipment, or other indirect, incidental or consequential damages.

INSTALLATION WARNINGS - These products should not be used to replace proper safety interlocking. No software-based device (or any other solid-state device) should ever be designed to be responsible for the maintenance of consequential equipment or personnel safety. In particular, SIXNET disclaims any responsibility for damages, either direct or consequential, that result from the use of this equipment in any application. All power, input and output (I/O) wiring must be in accordance with Class I, Division 2 wiring methods and in accordance with the authority having jurisdiction. Refer to section 1 for other important installation warnings.

FCC Statement - This equipment has been tested and found to comply with the limits for a Class B digital device, pursuant to Part 15 of the FCC Rules. These limits are designed to provide reasonable protection against harmful interference in a residential installation. This equipment generates, uses and can radiate radio frequency energy and, if not installed and used in accordance with the instructions, may cause harmful interference to radio communications. However, there is no guarantee that interference will not occur in a particular installation. If this equipment does cause harmful interference to radio or television reception, which can be determined by turning the equipment off and on, the user is encouraged to try to correct the interference by one or more of the following measures: Reorient or relocate the receiving antenna; Increase the separation between the equipment and receiver; Connect the equipment into an outlet on a circuit different from that to which the receiver is connected; Consult the dealer or an experienced radio/TV technician for help.

Copyright & Trademarks - Copyright ©2008 SIXNET, LLC. All Rights Reserved.

Note: All information in this document is subject to change without notice.

Section 1

General Information

Overview

The EK Series is a line of industrial Ethernet switches designed to be rack or wall mounted. Up to 32 Ethernet ports are offered including 8 Gigabit ports, 8 PoE ports and up to 20 fiber optic ports. The rugged and compact 1U packaging allows them to fit into standard EIA, WECCO and ETSI racks from 19 to 24".

This manual will help you install and maintain these industrial Ethernet switches. Installation of these switches is very easy and they will begin to operate as soon as they are powered up. Though these are fully managed switches, they will act as unmanaged until they are configured otherwise. Refer to the separate managed switch software manual for configuration of the advanced networking functionality and security.

Note: This manual only covers the installation and wiring of these switches. Refer to the separate **Software User Manuals** for details on configuring and using any of the management functions such as **SNMP, RSTP, IGMP, VLANs, security, port mirroring and much more.**

Basic Operation

Unlike an Ethernet hub that broadcasts all messages out all ports, these industrial Ethernet switches will intelligently route Ethernet messages only out the appropriate port. The major benefits of this are increased bandwidth and speed, reduction or elimination of message collisions, and deterministic performance when tied with real-time systems.

These industrial Ethernet switches can support 10BaseT (10 Mbps), 100BaseT (100 Mbps) and/or 1000BaseT (1000 Mbps) on their RJ45 ports (depending on the port). All of these ports will independently auto-sense the speed/duplex, mdi/mdix-crossover and polarity allowing you to use straight, crossed or even mis-wired cables. Also, these switches can optionally be equipped with many more fiber optic ports for making noise immune connections up to 120 km.

General Specifications

These general specifications apply to these industrial Ethernet switches. Refer to Section 7 for complete technical specifications.

Number of ports	Up to 32 Ethernet ports
Ethernet Switch Type	Managed
Ethernet Switch Mode	Store and forward, wire-speed, non-blocking
Ethernet Protocols	All standard IEEE 802.3 protocols supported
RJ45 Ports Speed	10/100 or 10/100/1000 Mbps
RJ45 Ports Operation	Auto-negotiation, auto-mdi/mdix-crossover and auto-polarity
Fiber Optic Port Speed	100 Mbps (SC or ST) or 1000 Mbps (SFP/LC)
Fiber Optic Type	Multimode, singlemode, long-haul or special application
Package style	1U 19" rack mount

Safety Standards



These industrial Ethernet Switches meet the following standards plus others:
(some qualifications may be pending – contact SIXNET for the latest information)

SIXNET, LLC is an ISO9001:2000 certified company (FM 65232) since 1996. These devices are design, developed and manufactured per an ISO9001 quality management system.



Electrical safety – These devices have been designed to meet the basic safety requirements of the following standards: (Approvals Pending)



- CE per Low Voltage Directive and EN 60950
- UL508
- CSA C22.2/14 (per cUL)



See warnings below.



Install the Managed Switches in accordance with local and national electrical codes.



Lightning Danger: Do not work on equipment during periods of lightning activity. Do not connect a telephone line into one of the Ethernet RJ45 connectors.



EMC (emissions and immunity) –

- CE per the EMC directive, EN 55022 or IEC 61326-1 or EN 61000-6-2/4
- FCC part 15 and ICES 003; Class B. **See FCC statement on previous page.**



Marine, maritime and offshore – These devices, when installed in an appropriately IP rated enclosure, comply with DNV No. 2.4 and equivalent Lloyds and ABS standards. **See warning below.**



For marine and maritime compliance, do not install this product within 5 meters of a standard or a steering magnetic compass.



Electric Utility Substations – These devices have been designed to meet or exceed the requirements of IEC 61850 and IEEE 1613 for use in power substations.



Traffic Control Systems – These devices have been designed to meet or exceed the requirements of NEMA TS-2 for use in traffic control systems.



WEEE compliance – These devices comply with the WEEE directive. Do not throw away these devices in the standard trash. Contact SIXNET regarding proper disposal.



RoHS compliance – These devices comply with the RoHS directive and are consider lead and other hazardous substance free.



Hazardous Locations – These devices have been designed to meet the requirements of the following hazardous locations standards. (Approvals Pending)

- CE per ATEX directive and EN50021/EN60079-15 (Zone 2);
EEx nA II T4 X (-40°C ≤ T_a ≤ +85°C)
- UL per UL1604 (Class I, Div. 2), Groups A,B,C,D
- CSA per C22.2/213 (Class 1, Div. 2), Groups A,B,C,D

See warnings below.



**WARNING
(EXPLOSION
HAZARD)**

SUBSTITUTION OF COMPONENTS MAY IMPAIR SUITABILITY FOR CLASS 1, DIVISION 2 (ZONE 2).



**WARNING
(EXPLOSION
HAZARD)**

WHEN IN HAZARDOUS LOCATIONS, DISCONNECT POWER BEFORE REPLACING OR WIRING UNITS.



**WARNING
(EXPLOSION
HAZARD)**

DO NOT DISCONNECT EQUIPMENT UNLESS POWER HAS BEEN SWITCHED OFF OR THE AREA IS KNOWN TO BE NONHAZARDOUS.



**WARNING
(EXPLOSION
HAZARD)**

IN HAZARDOUS OR POTENTIALLY HAZARDOUS LOCATIONS, DO NOT SEPARATE ANY PART OF THE UNIT WHEN ENERGIZED. USE THE UNIT FOR INTERNAL CONNECTIONS ONLY.

Important Note: The EK switches have no user serviceable parts. Any unauthorized service will void all warranties. In the unfortunate event that service is required please see the last section of this manual for information on how to contact SIXNET.

Section 2

Installation and Mounting

Overview

These industrial Ethernet switches are designed to be mounted in an industry standard rack or directly to any flat surface. Each switch is supplied with a standard set of 19" rack mounting brackets. Optionally, other mounting brackets are available. See the next page for details on utilizing the mounting brackets.

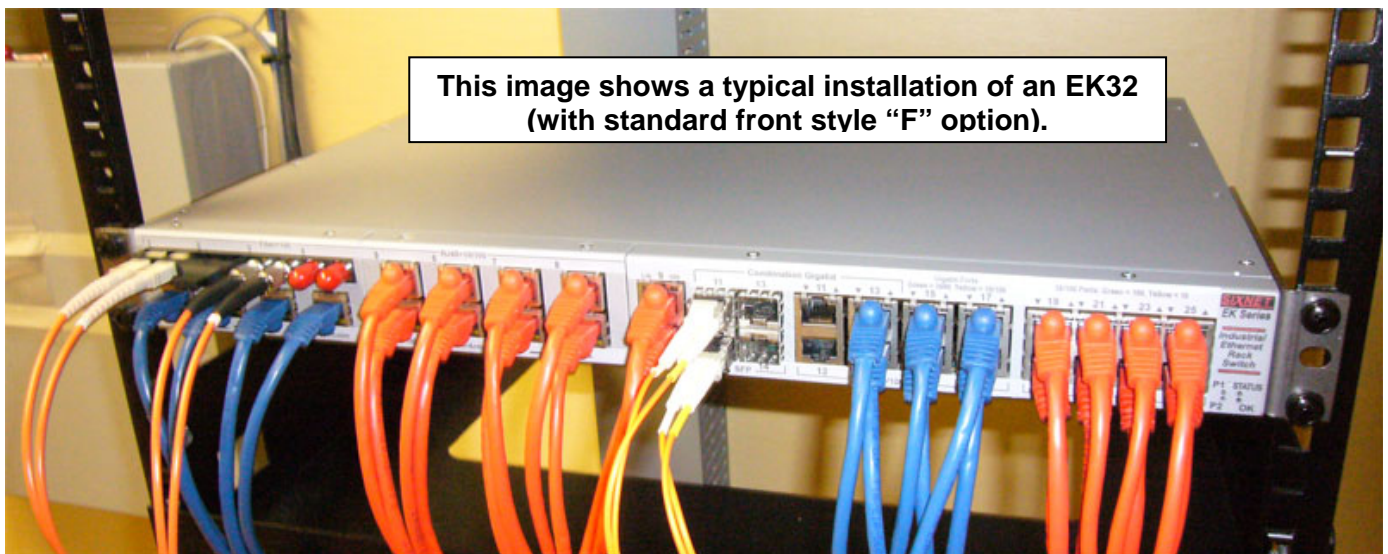
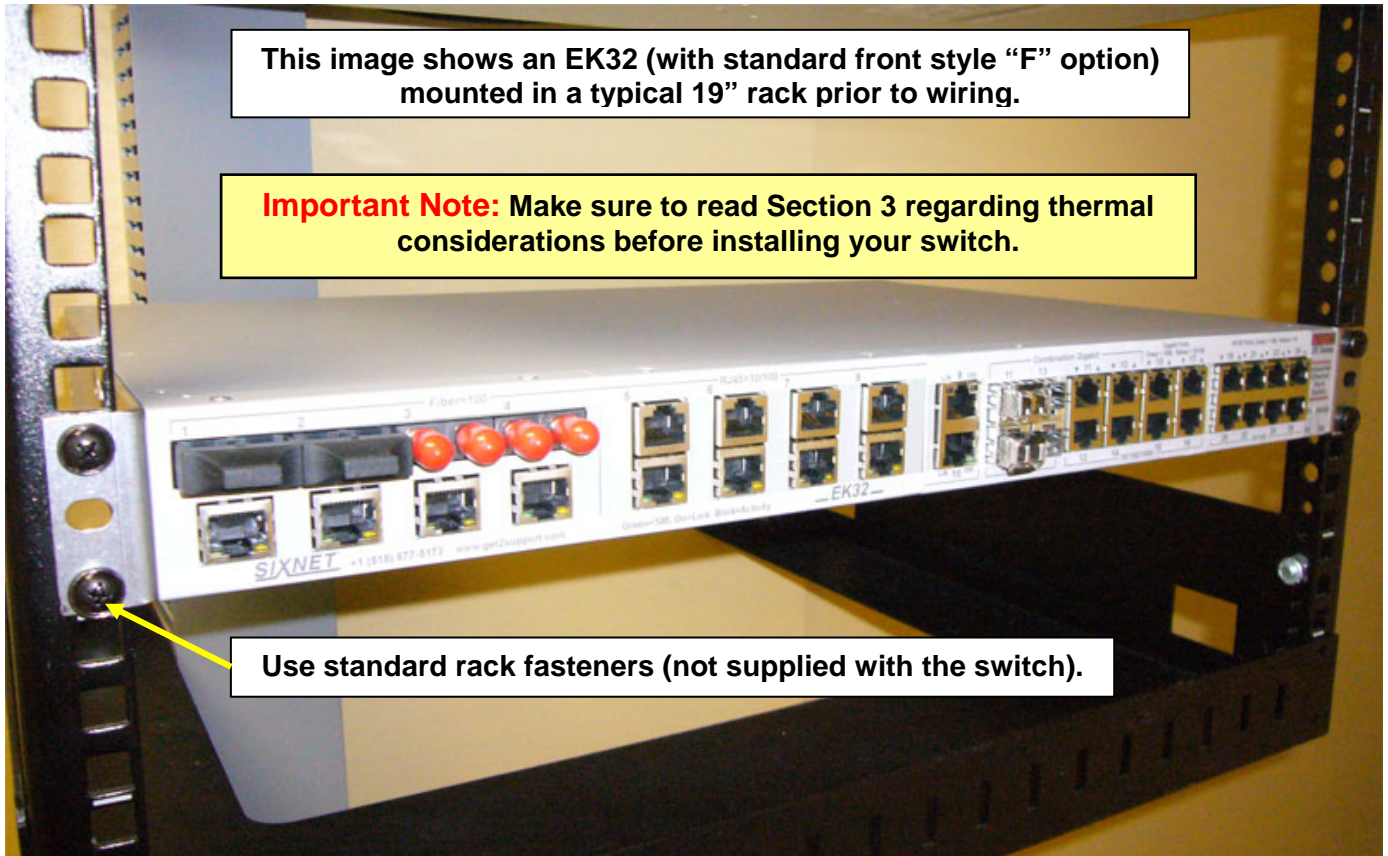

Mounting Brackets

There are many options for mounting these industrial Ethernet switches. Each switch is supplied with a standard set of 19" rack mounting brackets. Optionally, mounting brackets for 23", 24" and ETSI width racks are available. These mounting brackets universally support the mounting hole spacing per the EIA (1.25"), ETSI (25mm) and WECO (1.00") standards. Refer to the mechanical diagram on the next page for details.

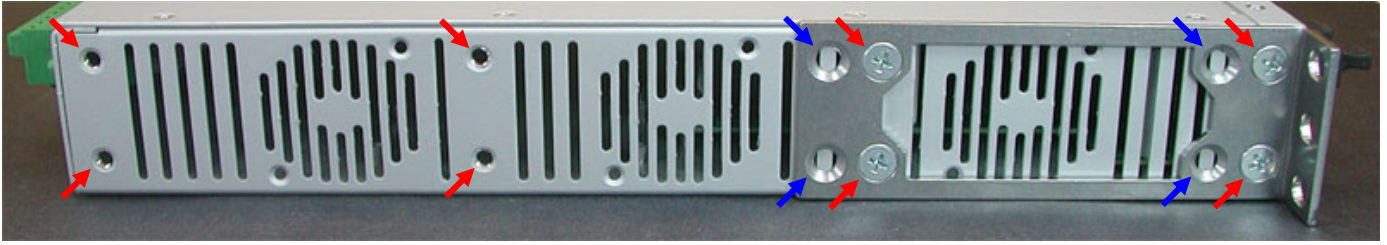

There are eight threaded inserts (see red arrows above) on each side of the switch that allow the brackets to be mounted in numerous positions for the best fit in your rack. The brackets also have extra holes (see blue arrows above) allowing them to be shifted right or left 1/2 inch. Use the four supplied screws to mount the bracket in the desired position. See below for images of a few of the possible mounting positions.



In the image above, the brackets are mounted flush with the front of the switch.



In the image above, the brackets are mounted flush with the back of the switch.



In the image above, the brackets are mounted so the front of the switch is setback 1/2 inch.



In the image above, the brackets are mounted in the middle of the switch to accommodate a centrally located rail.



For the most durable mounting you can use two brackets on each side (as shown in the image above). This is ideal for applications requiring the highest shock and vibration resistance.

Note: AutoCAD, Visio and 3D drawings are available at:
www.sixnet.com

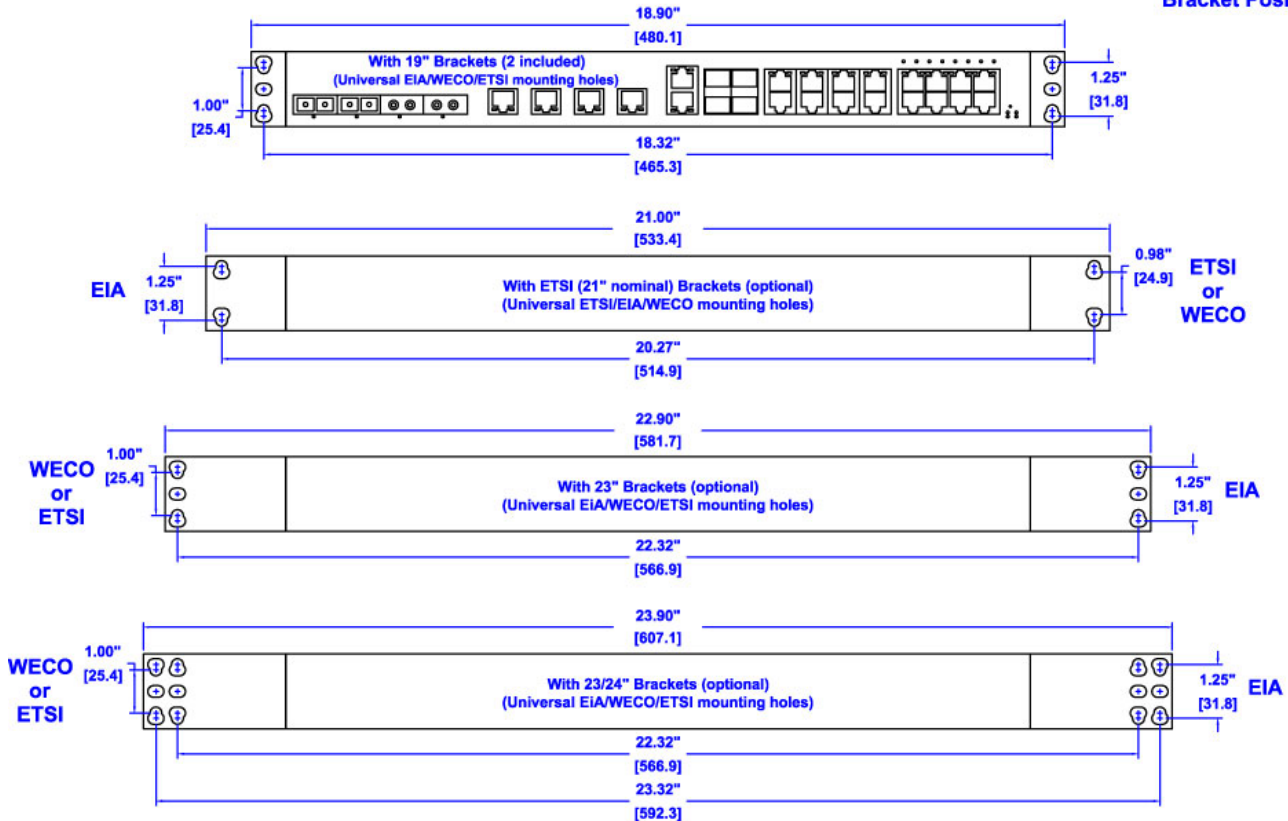
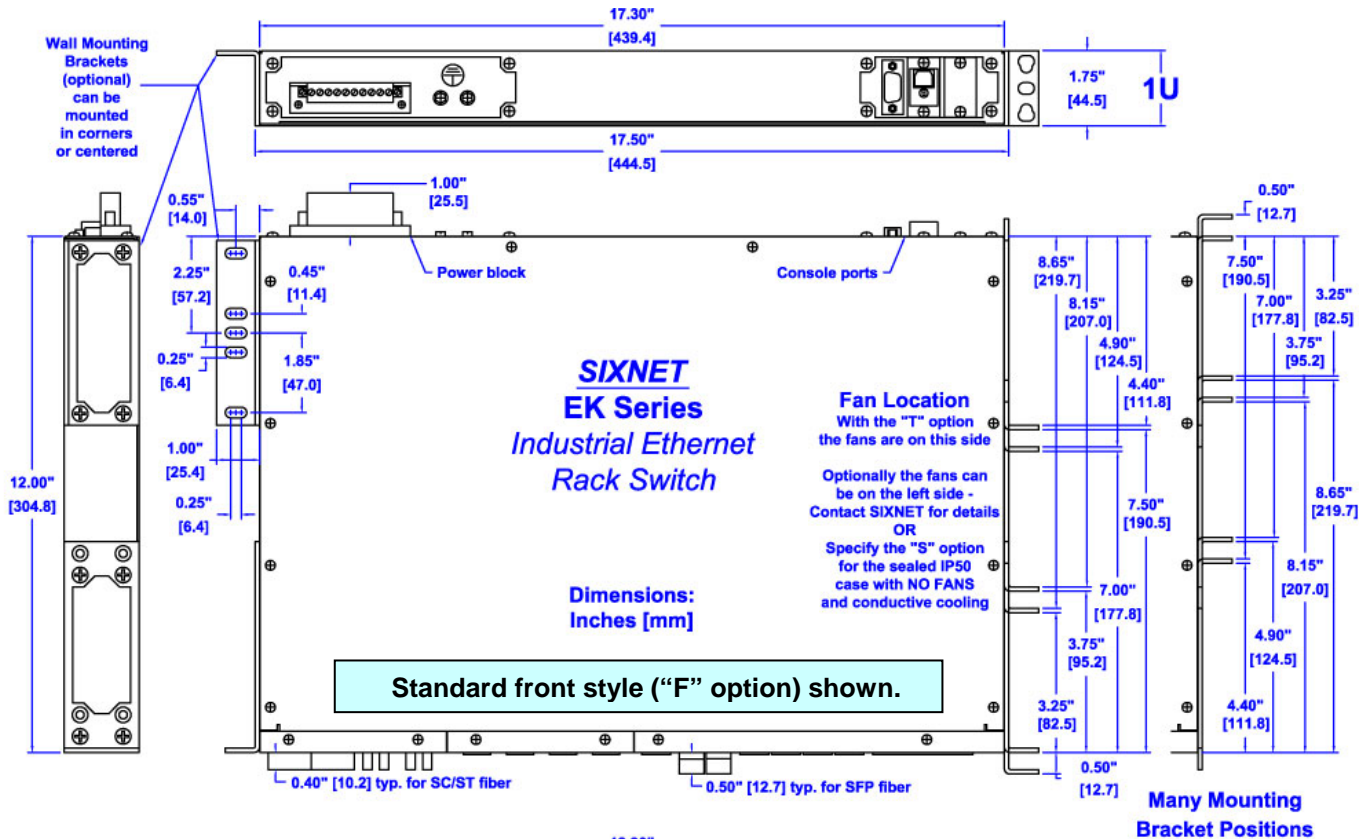

Mechanical Dimensions for the EK Series Switches and Brackets

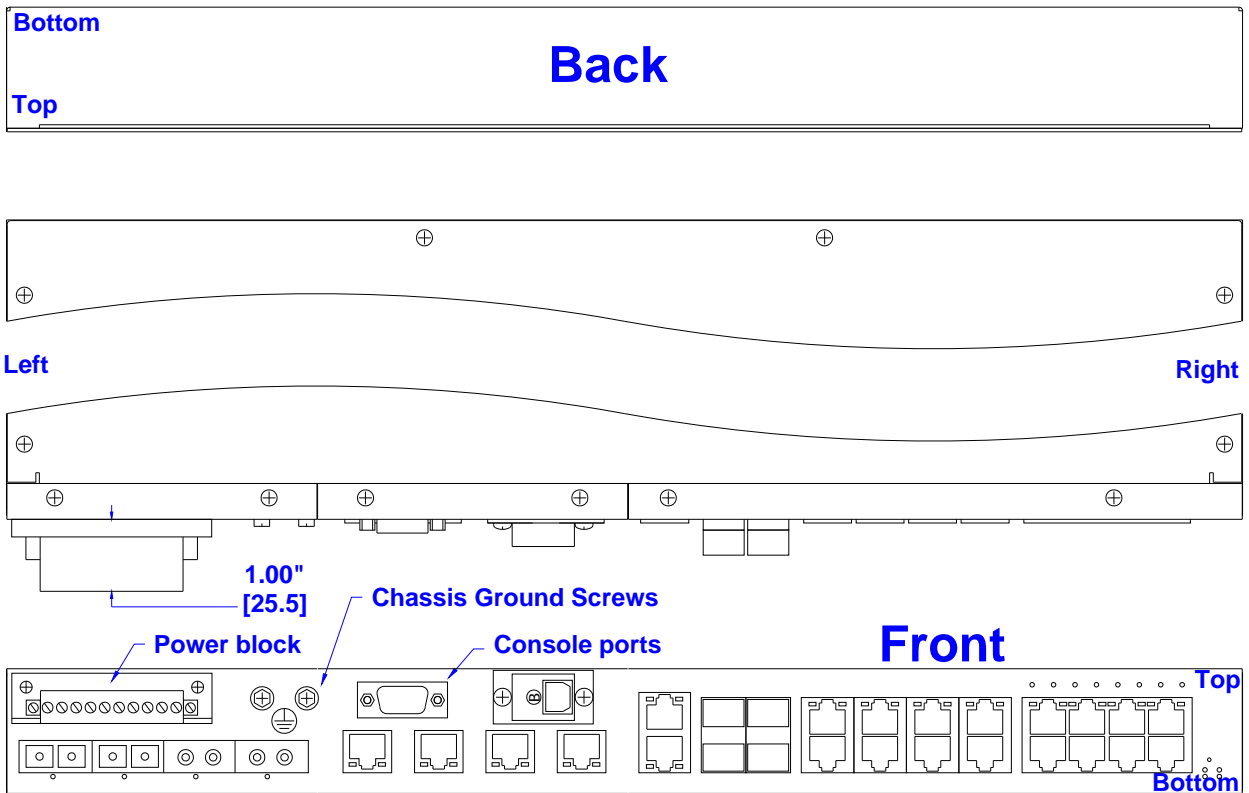

EK Switch with "G" Option (all connections in the front)

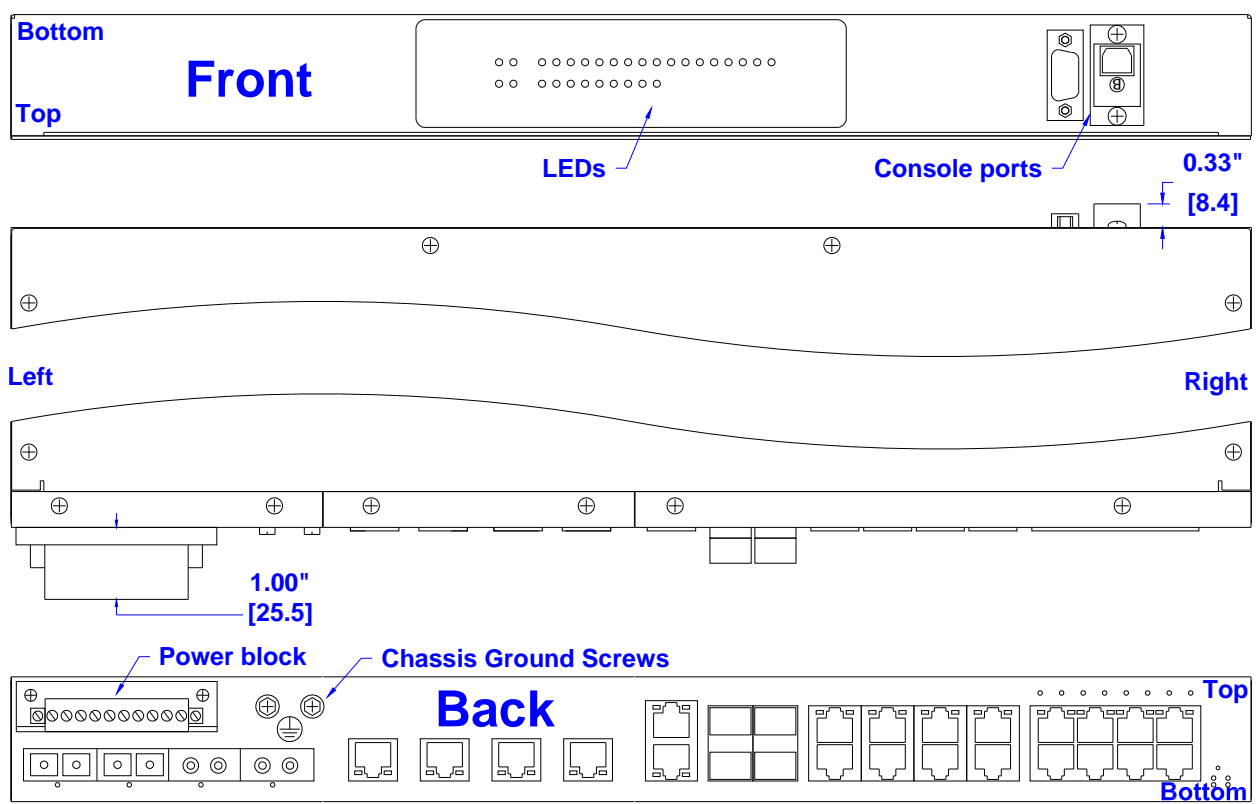

EK Switch with "R" (Reverse) Option

Section 3

Thermal Considerations

Overview

The EK Series Switches are design to operate from -40 to +85°C when they are installed properly. Two cooling options are offered: fan cooled and conduction cooled.

Fan Cooled "T" Models

These EK switch models are fan cooled and rated for operation from -40 to +85°C with cold startup at -40. No temperature derating is required. These models have the highest quality fans for long-term trouble-free operation. With the standard "T" option the fans are located inside the switch on the right side. The air flow is normally outward. Optionally (as a special order) the fans can be located on the left side or even in the back. Contact SIXNET for more information on these special options.

These models can be installed directly adjacent (vertically) to other devices in the rack. No extra air gaps are required. However, make sure not to block the air vent slots.

Important Note: Make sure to not block either the air inlet or outlet slots.

These fan cooled models are IP30 rated meaning they are protected against debris >2.5mm.

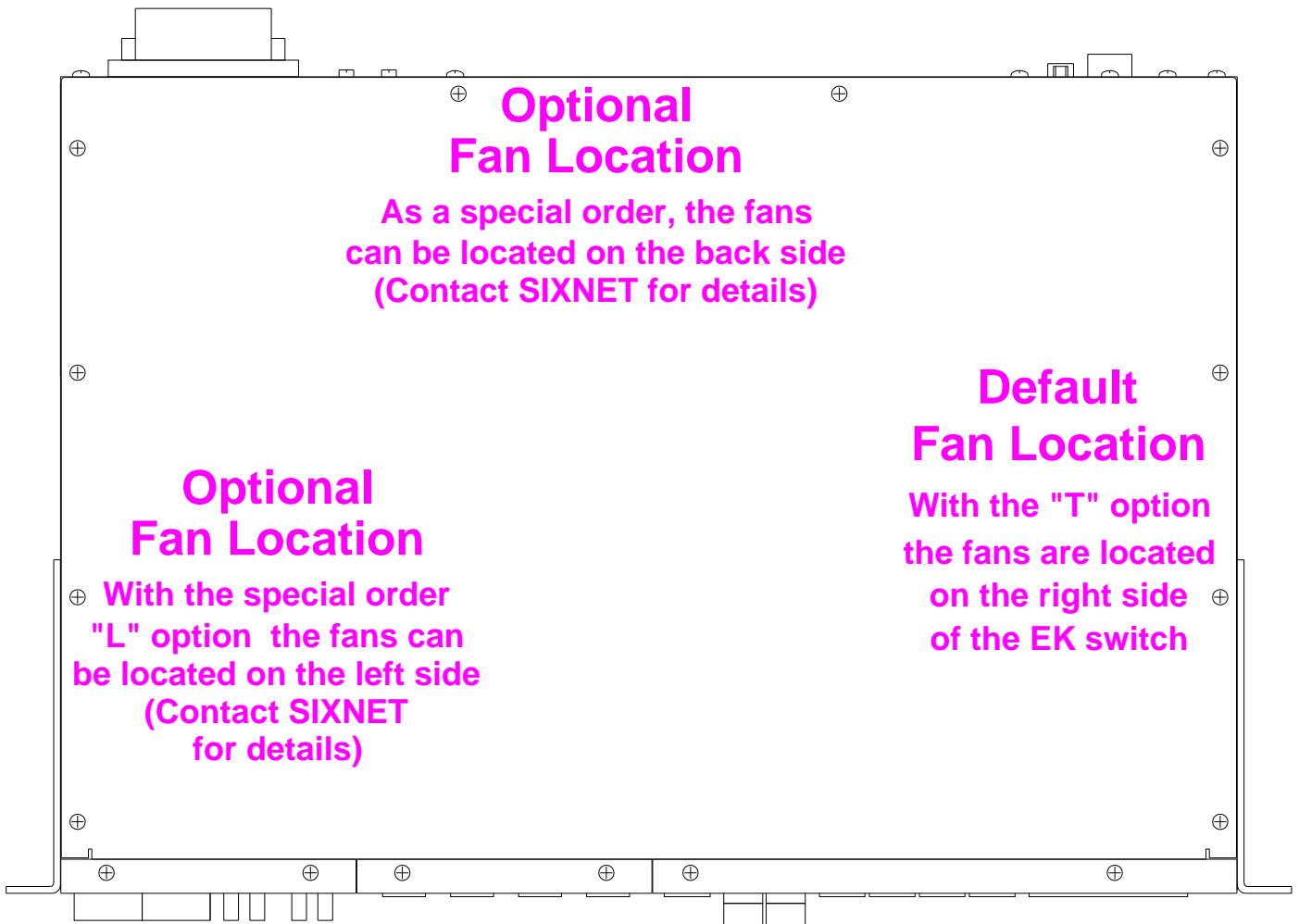

Fan Location in Fan Cooled Models

IP50 Sealed "S" Models

These EK switch models are conduction cooled and rated for operation from -40 to +85°C when there are no Gigabit connections. The cold startup rating (-40) is the same as the fan cooled models. When there are Gigabit connections then the temperature derating is as follows:

With no external air movement (free air convection):

- Maximum operating ambient temperature with 0 Gigabit connections = 85°C
- Maximum operating ambient temperature with 1 or 2 Gigabit connections = 75°C
- Maximum operating ambient temperature with 3 or 4 Gigabit connections = 70°C
- Maximum operating ambient temperature with 5 or 6 Gigabit connections = 65°C
- Maximum operating ambient temperature with 7 or 8 Gigabit connections = 60°C

Important Note:

These ratings are based on proper installation with respect to the thermal guidelines defined in this manual. Improper installation will reduce the temperature rating and possibly the operational life of the switch.

With 25 CFM of external air movement (forced air convection):

- Maximum operating ambient temperature with 0 to 4 Gigabit connections = 85°C
- Maximum operating ambient temperature with 5 to 8 Gigabit connections = 75°C

These "S" models are IP50 rated meaning they are mostly sealed against dust and debris.

These conduction cooled models utilize the aluminum case as a large heat sink. Heat is conducted from the inside of the switch to the case so that it can then be dissipated outside via convection. For best heat dissipation it is recommended that there be around 1/2U or more of free air space above and below the switch.

Suggestion:

If your space is limited and you must choose between an air gap on the bottom versus the top it is better to have the air gap on the bottom.

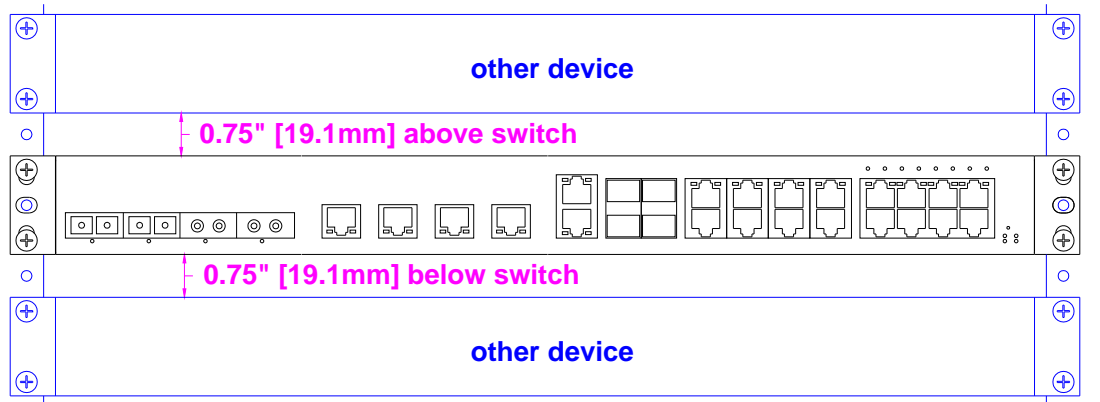

When rack mounting the "S" model (as shown above) it is recommended that there be some air space between the switch and any other devices directly above or below in the same rack.

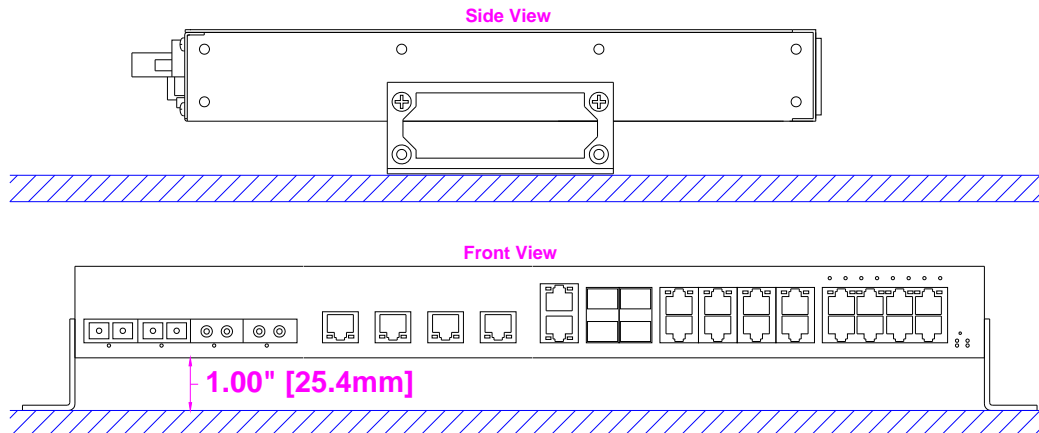

When wall mounting the "S" model it is recommended that the brackets be installed as shown above to provide some air space between the switch and the mounting surface.

Mounting and Cooling Alternative:

The bottom surface of the switch could be mounted flush (no air gap) to a suitable flat metal surface. A heat transfer pad (or paste) would be needed to conduct the heat from the switch case to the mounting surface. Contact SIXNET for more details.

Section 4

Power and Output Wiring

Overview



WARNING!
Make sure all power is OFF before wiring or unwiring any power connections to the switch!

The EK Series industrial Ethernet switches are offered with many power options including:

Standard Options:

Option D2 = dual +/-24 VDC power inputs – both P1 and P2 accept 18 to 36 VDC

Option D4 = dual +/-48 VDC power inputs – both P1 and P2 accept 36 to 75 VDC

Option A0 = single 110/220 VAC power input – P1 accepts 90-264 VAC or 130 to 370 VDC

Special Order Options:

Option D1 = dual +/-12 VDC power inputs – both P1 and P2 accept 9 to 18 VDC

Option H0 = single 110/125/250 VDC power input – P1 accepts 90-300 VDC

Option AA = dual 110/220 VAC – both P1 and P2 accept 90-264 VAC or 130 to 370 VDC

Option Ax = 110/220 VAC w/ VDC backup – P1 same as A0 & P2 same as Dx

The switch will have a power option specific label below the power input terminals (see image for an example). Make sure to reference this labeling when wiring your switch to make sure you are connecting the appropriate power to the correct terminals.

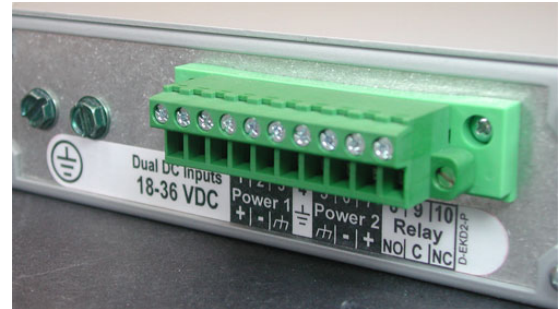

For the best safety always connect your earth / chassis grounds first!



The power input terminals and chassis ground screws may be located on either the front or back of the switch as shown in these images.



Safety Grounding

For the highest electrical safety the EK switches are provided with several grounding points. First, there are two green ground screws that attach directly to the switch case. These screws can be used to provide a NEBS compliant safety ground. Please follow all the NEBS grounding rules and your own local requirements (which are not documented in this manual) to ensure the safe operation of the switch. Alternatively, there is a chassis ground terminal (#4) that can be used to safety ground the switch. This terminal is internally tied to the switch case through a heavy-gauge ground wire. In addition, there is a ground terminal for each power input. Use these to terminate the ground wire for each of your power inputs.



WARNING!
Make sure all power is OFF
before wiring or unwiring any
power connections to the switch!

AC Power Systems

For AC powered systems the terminals will be labeled as “L” for Line (aka Hot), “N” for Neutral and the chassis ground symbol for ground. Connect your AC power input as appropriate. Typically the Line (Hot) lead is colored black or brown, the Neutral lead is colored white or blue and the ground is green or green/yellow.

Positive (+) DC Power Systems

For positive power systems (such as +24 VDC) put the positive lead on the terminal marked “+” and the return (or ground) lead on the terminal marked “-“. If there is a chassis, earth or safety ground lead then put it on the associated terminal marked with the chassis ground symbol.

Negative (-) DC Power Systems

The power options D1, D2 and D4 support negative power systems. If your power is negative (such as -48 VDC) then you must put the most positive lead on the + terminal. Always use a voltmeter to verify which lead is more positive. For dual power inputs the P1 and P2 polarity must match. For example, if you put a negative voltage on P1 and you also are connecting P2 then it must be a negative voltage as well.



ATTENTION!
For DC powered systems always
make sure the more positive lead
is connected to the “+” terminal.

Reverse Polarity Protection

The DC power inputs are reverse polarity protected. This means that if you swap the + and – leads then the switch will not be damaged.

Two #10-32 Screws for NEBS Compliant Safety Grounding

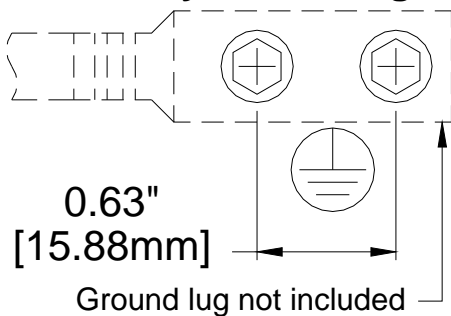

Pluggable Screw Block

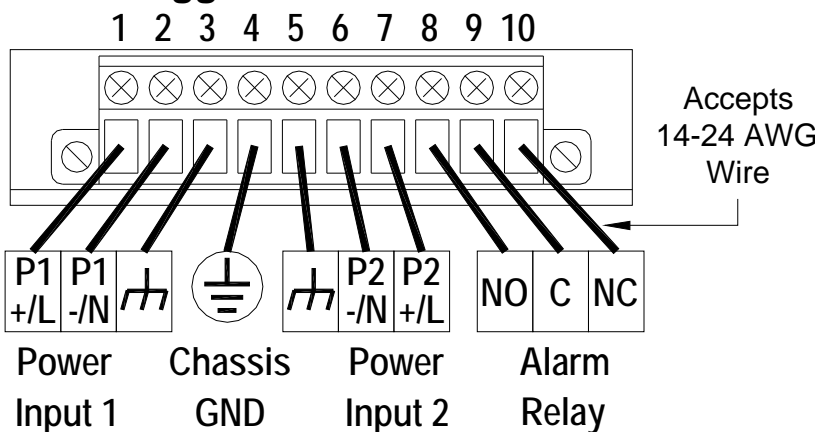

Power & Alarm Wiring for EK Series Switches

“OK” Alarm Output

The EK Series switches have an “OK” alarm output that can be tied to a PLC input, an alarm indicator (visible or audible) or other device to indicate when there is an alarm condition (such as the loss of a power input). The alarm output is a Form C relay with a normally open (NO), normally closed (NC) and common (C) screw terminal. Apply an appropriate power source to the common (C) terminal.

Alarm Output Ratings:

Maximum voltage = 250 VAC or 220 VDC

Maximum current = 2 A @ 30 VDC or 0.25 A @ 250 VAC

Minimum load = 10 mVDC, 10 μ A

The relay will operate as follows:

Condition	NO Contact	NC Contact
No power to switch	Closed (shorted to common)	Open
Switch powered with no alarms	Open	Closed (shorted to common)
Switch powered with an alarm	Closed (shorted to common)	Open

Wire Gauge & Screw Torque

The screw terminals are removable and secured by two screws. They will accept wire in the range of 24 to 14 AWG. When tightening the screws be careful to tighten to a maximum torque of 4.5 in/lb (0.51 Nm).

WIRING WARNINGS

Always install the Managed Switches in accordance with local and national electrical codes.

**WARNING
(EXPLOSION
HAZARD)**

SUBSTITUTION OF COMPONENTS MAY IMPAIR SUITABILITY FOR CLASS 1, DIVISION 2 (ZONE 2).

**WARNING
(EXPLOSION
HAZARD)**

WHEN IN HAZARDOUS LOCATIONS, DISCONNECT POWER BEFORE REPLACING OR WIRING UNITS.

**WARNING
(EXPLOSION
HAZARD)**

DO NOT DISCONNECT EQUIPMENT UNLESS POWER HAS BEEN SWITCHED OFF OR THE AREA IS KNOWN TO BE NONHAZARDOUS.

**WARNING
(EXPLOSION
HAZARD)**

IN HAZARDOUS OR POTENTIALLY HAZARDOUS LOCATIONS, DO NOT SEPARATE ANY PART OF THE UNIT WHEN ENERGIZED. USE THE UNIT FOR INTERNAL CONNECTIONS ONLY.



Section 5

Communication Ports Wiring

Overview

The EK Series switches provide connections to standard Ethernet devices such as PLCs, Ethernet I/O, industrial computers and much more. Three types of communication ports may be found on these switches: RJ45 (copper) Ethernet ports, fiber optic Ethernet ports and a console port (serial or USB) for management (managed models).

RJ45 Ethernet Wiring

Use data-quality (not voice-quality) twisted pair cable rated category 5 (or better) with standard RJ45 connectors. For best performance use shielded cable. Straight through or crossover RJ45 cable can be used regardless of the device the switch is to be connected to as all the ports are capable of auto-mdi/mdix-crossover detection.

The RJ45 Ethernet port connector bodies on these products are metallic and are connected to the Chassis GND terminal. Therefore, shielded cables may be used to provide further protection. To prevent ground loops, the cable shield should be tied to the metal connector body at one end of the cable only. Electrical isolation is also provided on the Ethernet ports for increased reliability.

For Reference Only.
Either cable wiring will work!

Straight-thru Cable Wiring	
Pin 1	Pin 1
Pin 2	Pin 2
Pin 3	Pin 3
Pin 6	Pin 6

Cross-over Cable Wiring	
Pin 1	Pin 3
Pin 2	Pin 6
Pin 3	Pin 1
Pin 6	Pin 2

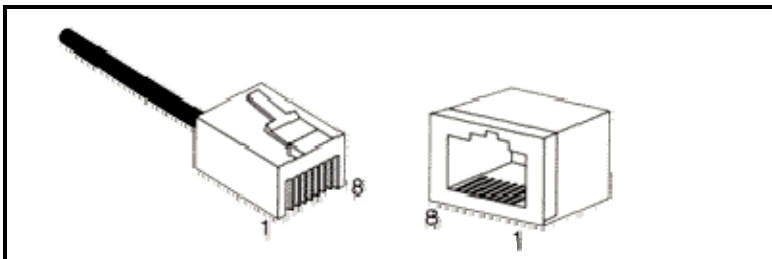

Ethernet Plug & Connector Pin Positions

RJ45 Cable Distance

The maximum cable length for 10/100/1000BaseT is typically 100 meters (328 ft.).

Ethernet Fiber Wiring Guidelines

Depending on the model the EK switches may have up to sixteen fixed 100Mb fiber optic ports. These fiber ports are available with dual SC, ST or FC style connectors. They are also available as multimode, singlemode, long-haul singlemode (for connections up to 120+ km) or special-application transceivers. Refer to the technical specifications for details.

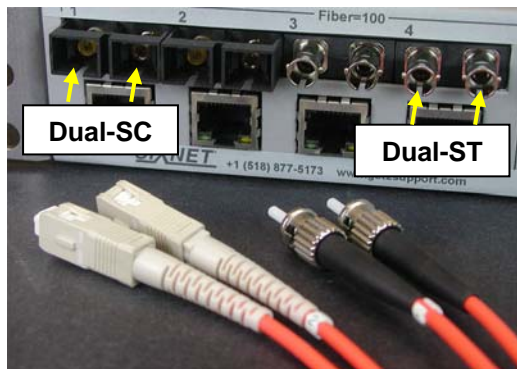

This image shows an EK switch with 2 dual-SC and 2 dual-ST fiber optic ports, plus the typical corresponding cabling.

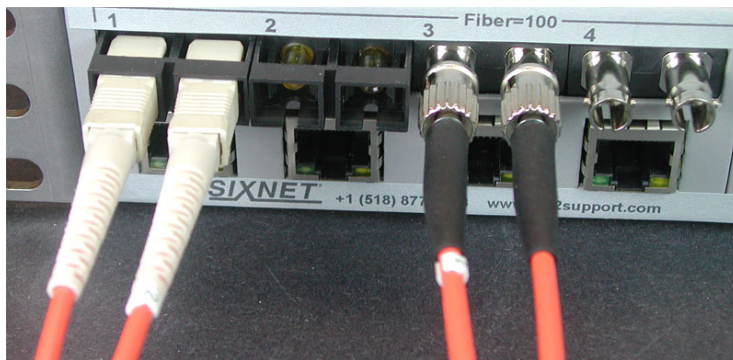

This image shows the fiber cables connected to the ports. The SC snap-in and the ST are a 1/4-turn bayonet style.

The EK switches may also have up to four pluggable fiber ports using mini-gbic SFP (small form pluggable) transceivers. These ports accept plug-in 100Mb or Gigabit (1000Mb) fiber transceivers that typically have an LC style connector. They are available as multimode, singlemode, long-haul singlemode (for connections up to 80+ km) or special-application transceivers. Refer to the technical specifications for details.

Important Note: When you make a fiber connection to one of the combination SFP / RJ45 ports then you cannot also use the associated copper RJ45 port at the same time (and vice versa). Which ever connector links first will take precedent and the other connector will become inactive.



This image shows a typical SFP/LC transceiver and dual-LC cable.

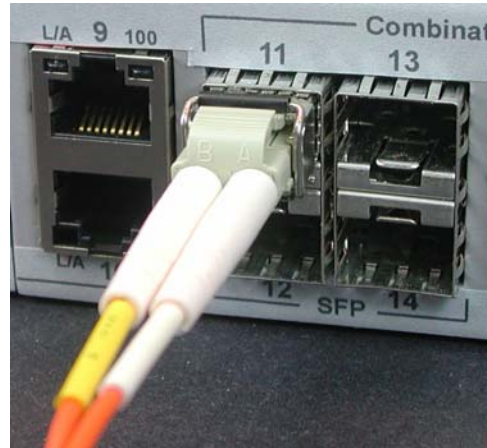

This image shows the SFP/LC transceiver and dual-LC cable plugged into the switch.

For each fiber port there is a transmit (TX) and receive (RX) signal. When making your fiber optic connections, make sure that the transmit (TX) port of the switch connects to the receive (RX) port of the other device, and the receive (RX) port of the switch connects to the transmit (TX) port of the other device. See the diagram below to determine which fiber connection is transmit (TX) versus Receive (RX) for each of the possible fiber connections.

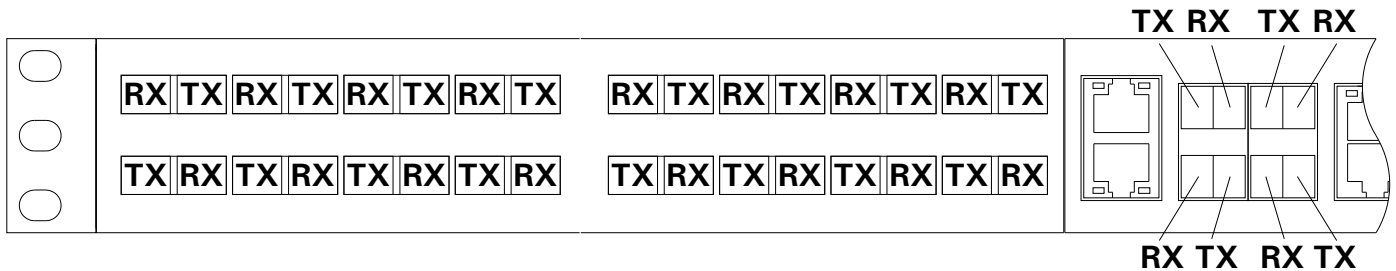

Use standard fiber optic wiring techniques (not covered by this manual) to make your connections. The corresponding ACT/LNK LED will be ON solid or flashing when you have made a proper connection. For more fiber optic guidelines go to:

www.sixnet.com

Duplex Operation

The RJ45 ports will auto-sense for Full or Half duplex operation, while the fiber ports default to full duplex operation or can be configured for Full or Half duplex. Refer to the software user manual for details on the software configuration options.

Verifying Connectivity

After all Ethernet and/or fiber connections are made, check the LED's corresponding to the ports that each of the devices are connected to. Ensure that for each port that is in use, the LED is on or blinking. If a port LED is off, go back and check for connectivity problems between that port and the network device connected to that particular port. In addition, the color of the LED should indicate the speed for which your device is connected at (see the next section on the status LEDs).

Console Port Management

This manual only details how to make a physical connection to the serial and USB console ports. Refer to the software user manual for details on how to configure the switch.

The switch can be software configured by the following methods:

- Web user interface
- Text user interface via one of the **console ports**, Telnet or SSH (Secure Shell)
- CLI (Command Line Interface) via one of the **console ports**, Telnet or SSH
- SNMP v1, v2 or v3

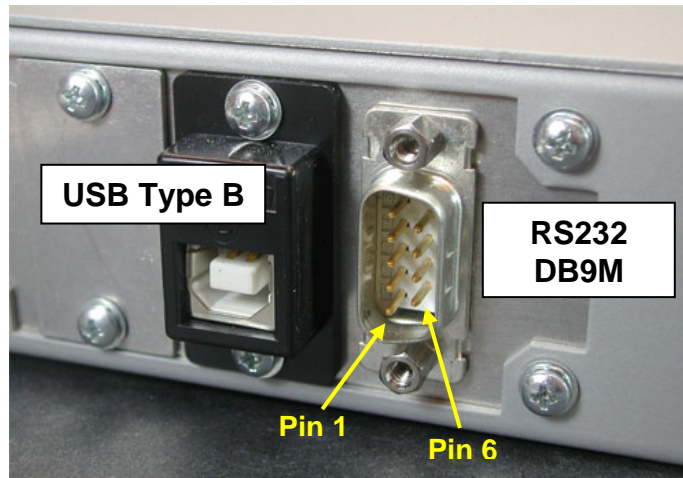

The console ports may be located on either the front or back of the switch as shown in these images.



Serial DB9 Console Port

The switch has a standard RS232 male DB9 serial port as shown in the image above. The pin-outs are defined below. Use a standard “null-modem” cable between your PC and the switch. This cable is not supplied but is available from any computer store. If your PC does not have a serial DB9 port then you can purchase an inexpensive USB to Serial converter from any computer store, or use the USB port on the switch.

Switch DB9 Male		Typical Null-modem Cable DB9F to DB9F	PC DB9 Male	
RJ45F Pin #	Signal Name		Signal Name	RJ45F Pin #
1	CD in		CD in	1
2	RD in		RD in	2
3	TD out		TD out	3
4	DTR out		DTR out	4
5	GND		GND	5
6	DSR in		DSR in	6
7	RTS out		RTS out	7
8	CTS in		CTS in	8
9	RI in		RI in	9

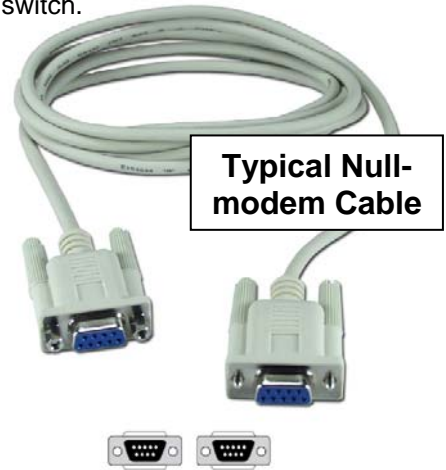

USB Type B Console Port

As an alternative to the traditional serial port, the EK Series switches also have a female type B (slave) USB port. See the image above. Use a standard USB cable with a male USB type B (for the switch connection) to a male USB type A (for the PC connection). This cable is not supplied but is available from any computer store. See the image below.

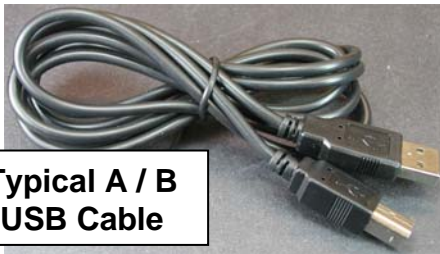

Male USB Type B



Note: Once you have made a physical connection to either the serial or USB port then refer to the software user manual for how to access the switch.

Section 6

LED Indicators

Overview

The EK Series switches have 1 or 2 communication LEDs for each port, dual power LEDs, an “OK” output LED and an overall status LED.



Typical LED Locations (may vary with model)

Ethernet Group 1

Ethernet Group 1 are ports 1 through 10 on an EK26 or 1 through 18 on an EK32. These ports may be copper RJ45 or fixed fiber optic ports. See image below.

For the fixed fiber optic ports there is one LED per port. This LED is located either directly below or above the fiber connector.

Fixed Fiber Port LED Status: (these ports are always 100Mb)

Green LED ON Solid	Link Only - Indicates that there <u>is</u> a proper Ethernet connection (Link) but no communications activity is detected.
Green LED ON Flashing	Link & Activity - Indicates that there <u>is</u> a proper Ethernet connection (Link) and communications activity is detected.
OFF	No link - Indicates that there <u>is not</u> a proper Ethernet connection (Link). Make sure the cable has been properly connected at both ends.

For the copper RJ45 ports there are two LEDs per port integrated in the connector.

RJ45 Copper Port LED Status:

Yellow LED ON Solid	Link Only - Indicates that there <u>is</u> a proper Ethernet connection (Link) but no communications activity is detected.
Yellow LED ON Flashing	Link & Activity - Indicates that there <u>is</u> a proper Ethernet connection (Link) and communications activity is detected.
Yellow LED OFF	No link - Indicates that there <u>is not</u> a proper Ethernet connection (Link). Make sure the cable has been properly connected at both ends.
Green LED ON Solid	100 Mbps - The port has linked at 100 Mbps.
Green LED OFF	10 Mbps - The port has linked at 10 Mbps or there is no link.



Ethernet Port Group 1

Ethernet Group 2

Ethernet Group 2 are ports 11 through 18 on an EK26 or 19 through 24 on an EK32. These ports are Gigabit (10/100/1000 Mb) on EK models or Fast (10/100 Mb) on EF models. There is only one LED per port. The triangles on the labeling indicate which port (upper or lower) the LED belongs to. See the image below.

Note: The SFP ports (if present) each share an LED with their associated RJ45 port.

Gigabit Port LED Status: (reference image below)

ON Solid Green	1000 Mb Link Only - Indicates that there <u>is</u> a proper Gigabit Ethernet connection (Link) but no communications activity is detected.
ON Solid Yellow	100 or 10 Mb Link Only - Indicates that there <u>is</u> a proper 10/100 Ethernet connection (Link) but no communications activity is detected.
Flashing (either color)	Activity - Indicates that communications activity is detected.
OFF	No link - Indicates that there is <u>not</u> a proper Ethernet connection (Link). Make sure the cable has been properly connected at both ends.

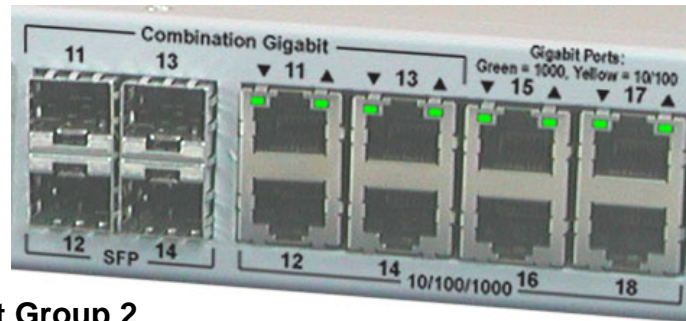

Ethernet Port Group 2

Ethernet Group 3 (non-PoE models)

Ethernet Group 3 are ports 19 through 26 on an EK26 or 25 through 32 on an EK32. These ports are 10/100 Mb and there is only one LED per port. The triangles on the labeling indicate which port (upper or lower) the LED belongs to. See the image below.

10/100 Port LED Status: (reference image below)

ON Solid Green	100 Mb Link Only - Indicates that there <u>is</u> a proper 100 Mb Ethernet connection (Link) but no communications activity is detected.
ON Solid Yellow	10 Mb Link Only - Indicates that there <u>is</u> a proper 10 Mb Ethernet connection (Link) but no communications activity is detected.
Flashing (either color)	Activity - Indicates that communications activity is detected.
OFF	No link - Indicates that there is <u>not</u> a proper connection (Link). Make sure the cable has been properly connected at both ends.

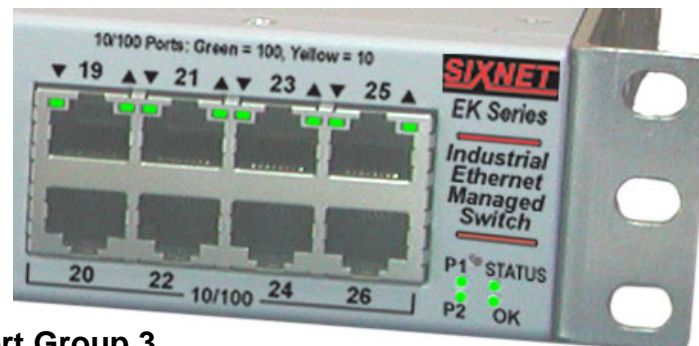

Ethernet Port Group 3

Ethernet Group 3 (PoE models)

Ethernet Group 3 are ports 19 through 26 on an EK26 or 25 through 32 on an EK32. These ports are 10/100 Mb with PoE and there is two LEDs per port. One LED indicates the link and activity and the other indicates the PoE status.

10/100 Port LED Status: (reference image below)

ON Solid Green	100 Mb Link Only - Indicates that there <u>is</u> a proper 100 Mb Ethernet connection (Link) but no communications activity is detected.
ON Solid Yellow	10 Mb Link Only - Indicates that there <u>is</u> a proper 10 Mb Ethernet connection (Link) but no communications activity is detected.
Flashing (either color)	Activity - Indicates that communications activity is detected.
OFF	No link - Indicates that there <u>is not</u> a proper connection (Link). Make sure the cable has been properly connected at both ends.

PoE LED Status:

ON	Power Active - Indicates that the port <u>is</u> sourcing power.
OFF	No PoE Power - Indicates that the port <u>is not</u> sourcing power.

Status LED

The Status LED indicates the overall health of the switch. It is normally ON solid indicating that no internal CPU or software problems are detected. It will flash when loading firmware and briefly on power up or reset. Otherwise, if it is OFF or flashing for an extended period of time then a problem is detected. In this case, please contact SIXNET for support.

Power LEDs

There are two Power LEDs (labeled P1 for primary power and P2 for backup power) that indicate if there is power applied to the respective input.

“OK” Alarm LED

The “OK” LED indicates the status of the alarm relay output. This LED will be normally ON when there is no alarm or error condition (such as loss of a power input). Otherwise, when there is an alarm then it will be OFF.

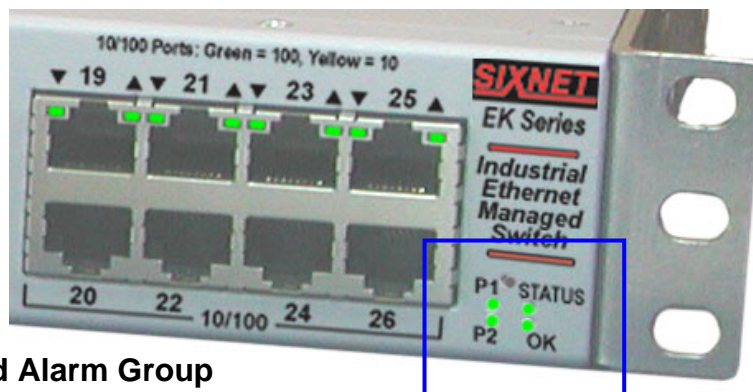

Status, Power and Alarm Group

Section 7

Reset Button

Reset Button

A reset button has been provided in the event that a full hardware reset of the switch is required. The reset button is accessed through a small hole in the front of the switch near the status LED. See the image below. Simply use a straightened paper clip to push in the reset button. There are two modes of operation as described below.

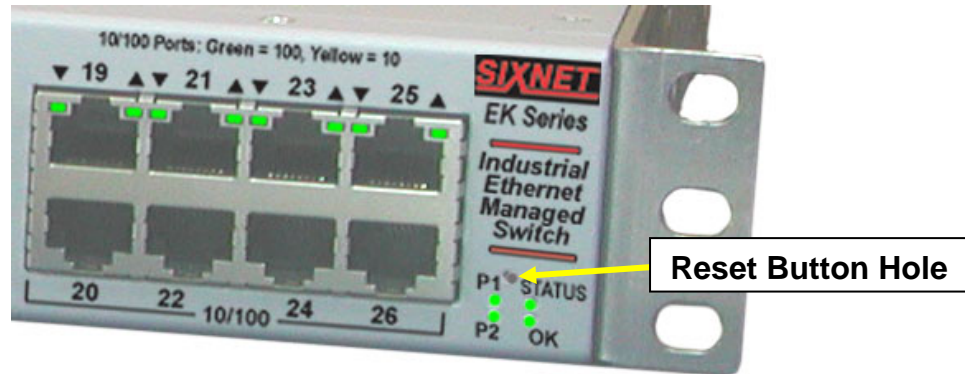

Hardware Reset

To simply perform a hardware reset just push in the reset button momentarily. The switch will then immediately perform a hardware reset which takes around 30 seconds. The switch will not function or be accessible during this period.

Restore Factory Defaults

To perform a hardware reset and restore the switch to the factory defaults then push in and hold the reset button for at least 5 seconds. The switch will then reset and afterwards restore ALL configuration settings back to the factory defaults.

Section 8

Technical Specifications

Technical Specs

Here are the hardware technical specifications for the EK Series switches covered by this manual. Refer to the software user manual or datasheet for complete software specifications.

Note: These specifications are subject to change. Contact SIXNET for the latest details.

EK26 Performance Specifications

General	26 or 32 Ethernet ports total
Ethernet switch type	Managed, store & forward, non-blocking
Ethernet compliance	IEEE 802.3, 802.3u, 802.3z/ab, 802.3x, 802.1D/w, 802.1p, 802.1Q and more
MAC addresses & memory bandwidth	8192 & 32 Gbps
Typ. latency for 100 Mbps	<5 us + frame time (varies on load)
Ethernet isolation	1500 VRMS 1 minute

All RJ45 Copper Ports	Up to 26 RJ45 copper ports (8 Gigabit and 18 fast) Up to 32 RJ45 copper ports (6 Gigabit and 26 fast)	
RJ45 speed and duplex (full or half)	Auto-negotiation or configurable	
RJ45 MDI/MDIX and polarity (TD/RD)	Auto-MDI/MDIX-crossover and Auto-polarity	
Fast Ethernet (FE) Fiber Ports	Up to 16 with SC or ST or FC connectors	Note: See further in this datasheet for more SC and ST fiber transceiver specifications.
FE fiber optic speed & max distance	100 Mbps up to 120 km	
FE fiber optic type	Multimode or singlemode	
FE fiber optic wavelengths (typical)	1310 or 1550 nm	
Gigabit Ethernet (GE) Ports	6 or 8 total Gigabit Ethernet ports, 10/100/1000 RJ45 on each port	
Note: Four of the Gigabit ports are combination ports that have both a RJ45 connector and SFP fiber connector. For each of these ports, only one of the connectors can be used at a time.		
GE SFP (pluggable) ports	4 for mini-GBIC transceivers	Note: See further in this datasheet for more SFP fiber transceiver specifications.
GE fiber optic speed & max distance	1000 or 100 Mb up to 80 km	
GE fiber optic wavelength (typical)	850 nm , 1310 nm or 1550 nm	
Fast Ethernet (FE) PoE Ports	Up to 8 that are fully IEEE 802.3af compliant	
PoE classification	PSE (Power Sourcing Equipment)	
PoE power output	Up to 15.4 W per port (120 W total max. power with D4 option – no derating) (60 W total max. power with A0 option at 75 °C; 100 W max. at 50 °C)	
PoE RJ45 pin assignments	RX+/VDC+ on pins 1 and 2; TX-/VDC- on pins 3 and 6; (pins 4, 5, 7 and 8 unused)	
PoE operation	Automatic detection and power management; DC disconnect	
PoE protection	Over-temperature, over-current, over/under-voltage and transient	

Console Ports	2 for local switch management
RS232 serial port	DB9, male, DTE (2 = RXD in, 3 = TXD out, 5 = GND)
USB slave port	Type B, female

Alarm Output	1 form C relay with NC (normally closed) and NO (normally open) terminals
Maximum voltage and current	250 VAC or 220 VDC or 2 A @ 30 VDC or 0.25 A @ 250 VAC
Minimum load	10 mVDC, 10 µA

Power Input	18-36 VDC (24 VDC nominal), dual input;	
Standard input voltage options	36-75 VDC (+/-48 VDC nominal), dual input; 90-264 VAC or 130-370 VDC (110/220 VAC nominal)	
Special order input voltage options	9-18 VDC (12 VDC nominal), dual input; 90-300 VDC (110/125/250 VDC nominal)	Other options available – Contact SIXNET for details
Special order power options	Redundant AC inputs/supplies, AC with DC backup and more	
Input power consumption	27 W or 35 W maximum (with 12 or 20 fiber ports)	
Surge protection (9-75 VDC inputs)	Transient - 15,000 watts peak; Spike - 5,000 watts (10 times for 10 µs)	

Environmental	T option (fan cooled): -40 to +85 °C (no derating) (cold startup at -40 °C)	
Operating temperature range	S option (sealed IP50): -40 to +85 °C with all ports linked at 10 or 100Mb (derate to +75 °C with 2 ports linked at Gigabit, +70 °C with 4 Gigabit links, +65 °C with 6 Gigabit links or +60 °C with 8 Gigabit links)	
Storage temperature range	-40 to +85 °C (-40 to 185 °F)	
Humidity (non-condensing)	5 to 95% RH	Conformal coating is available – contact SIXNET for details
Vibration and shock	IEC 60068-2-6, -2-27; IEC 60970-2-2	

Standards and Compliances	UL508, CSA per cUL, CE	(pending)
EMC emissions & immunity	FCC part 15, ICES-003, CE	
Power substations	Designed for IEEE 1613 and IEC 61850	
Traffic control systems	Designed for NEMA TS2	
Railways network systems	Designed for EN50121-5	
Marine and maritime	Designed for ABS, DNV and GL (Germanischer Lloyd)	

Mechanical	1U rack-mount (19" brackets included) (optional ETSI, 23" and 24" brackets)	
Mounting	19" to 24" racks, EIA/WECO/ETSI brackets available	
Case construction	Corrosion-resistant heavy-gauge aluminum	
Case protection	IP50 with S (sealed) option or IP30 / NEMA 2 with T option	
Dimensions (L x W x H) nominal	1.75 x 17.3 x 12 inches (44.5 x 439.4 x 305.0 mm)	
Weight (typical)	5.5 lbs (2.5 kg) – may vary slightly by model	

Specifications are subject to change. Consult factory for latest information.

Note: See the separate fiber optic transceiver datasheets for complete specifications. Also, other fiber transceivers may be available for special requirements such as longer distances, single strand or other special applications. Contact SIXNET for details.

Section 9

Service Information

Service Information

We sincerely hope that you never experience a problem with any **SIXNET** product. If you do need service, call **SIXNET** at (518) 877-5173 and ask for Applications Engineering. A trained specialist will help you to quickly determine the source of the problem. Many problems are easily resolved with a single phone call. If it is necessary to return a unit to us, an RMA (Return Material Authorization) number will be given to you.

SIXNET tracks the flow of returned material with our RMA system to ensure speedy service. You must include this RMA number on the outside of the box so that your return can be processed immediately.

The applications engineer you are speaking with will fill out an RMA request for you. If the unit has a serial number, we will not need detailed financial information. Otherwise, be sure to have your original purchase order number and date purchased available.

We suggest that you give us a repair purchase order number in case the repair is not covered under our warranty. You will not be billed if the repair is covered under warranty.

Please supply us with as many details about the problem as you can. The information you supply will be written on the RMA form and supplied to the repair department before your unit arrives. This helps us to provide you with the best service, in the fastest manner. Normally, repairs are completed in two days. Sometimes difficult problems take a little longer to solve.

If you need a quicker turnaround, ship the unit to us by air freight. We give priority service to equipment that arrives by overnight delivery. Many repairs received by mid-morning (typical overnight delivery) can be finished the same day and returned immediately.

We apologize for any inconvenience that the need for repair may cause you. We hope that our rapid service meets your needs. If you have any suggestions to help us improve our service, please give us a call. We appreciate your ideas and will respond to them.

For Your Convenience:

Please fill in the following and keep this manual with your **SIXNET** system for future reference:

P.O. #: _____ Date Purchased: _____

Purchased From: _____

Product Support

To obtain support for SIXNET products:

Latest product info: <http://www.sixnet.com>

Phone: +1 (518) 877-5173

Fax: +1 (518) 877-8346

E-mail: <mailto:support@sixnet.com>

Address: SIXNET Technology Park, 331 Ushers Road, Ballston Lake, NY 12019