

EtherTRAK[™] *Industrial Ethernet* **Real-time Switches**

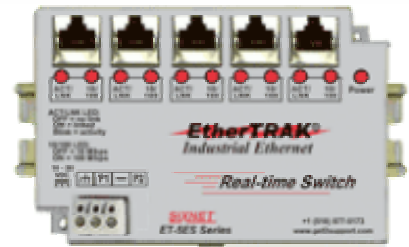

Contents at a Glance:

Section 1	General Information	Page 3
Section 2	LED Indicators	Page 4
Section 3	Installation	Page 5
Section 4	Power Wiring	Page 6
Section 5	Ethernet Wiring	Page 7
Section 6	Switching Features	Page 9
Section 7	Technical Specifications	Page 11
Section 8	Service Information	Page 13

Applicable standards and certifications:



This manual applies to the following products:

- ET-5ES-##
- ET-GT-9ES-##

SIXNET Protected Technology Policy:

SIXNET protects your investment in SIXNET systems with long-term planned technology and our unique Protected Technology Policy. We will continue to support the specified capabilities of standard SIXNET products for at least five years. We plan each product improvement and new feature to be upward compatible with existing designs and installations. Our goals are to make each new software release bring new power to your SIXNET systems and have every existing feature, applications program and data file continue to work. We protect your investment even further with a liberal five-year trade-in policy. Exchange standard products for upgraded versions of the same product to take advantage of new features and performance improvements at any time for five years. A prorated trade-in allowance will be given for your existing equipment. SIXNET protects your long-term productivity with state-of-the-art planned technology and continued support.

SIXNET Statement of Limited Warranty:

Digitronics SIXNET ('SIXNET'), manufacturer of SIXNET products, warrants to Buyer that products, except software, manufactured by SIXNET will be free from defects in material and workmanship. SIXNET's obligation under this warranty will be limited to repairing or replacing, at SIXNET's option, the defective parts within one year of the date of installation, or within 18 months of the date of shipment from the point of manufacture, whichever is sooner. Products may be returned by Buyer only after permission has been obtained from SIXNET. Buyer will prepay all freight charges to return any products to the repair facility designated by SIXNET. This limited warranty does not cover losses or damages which occur in shipment to or from Buyer or due to improper installation, maintenance, misuse, neglect or any cause other than ordinary commercial or industrial applications. In particular, SIXNET makes no warranties whatsoever with respect to implied warranties of merchantability or fitness for any particular purpose. All such warranties are hereby expressly disclaimed. No oral or written information or advice given by SIXNET or SIXNET's representative shall create a warranty or in any way increase the scope of this warranty. This limited warranty is in lieu of all other warranties whether oral or written, expressed or implied. SIXNET's liability shall not exceed the price of the individual units, which are the basis of the claim. In no event shall SIXNET be liable for any loss of profits, loss of use of facilities or equipment, or other indirect, incidental or consequential damages.

INSTALLATION AND HAZARDOUS AREA WARNINGS:

These products should not be used to replace proper safety interlocking. No software-based device (or any other solid-state device) should ever be designed to be responsible for the maintenance of consequential equipment or personnel safety. In particular, SIXNET disclaims any responsibility for damages, either direct or consequential, that result from the use of this equipment in any application.

All power, input and output (I/O) wiring must be in accordance with Class I, Division 2 wiring methods and in accordance with the authority having jurisdiction.

- WARNING (EXPLOSION HAZARD) -** SUBSTITUTION OF COMPONENTS MAY IMPAIR SUITABILITY FOR CLASS 1, DIVISION 2.
- WARNING (EXPLOSION HAZARD) -** WHEN IN HAZARDOUS LOCATIONS, DISCONNECT POWER BEFORE REPLACING OR WIRING UNITS.
- WARNING (EXPLOSION HAZARD) -** DO NOT DISCONNECT EQUIPMENT UNLESS POWER HAS BEEN SWITCHED OFF OR THE AREA IS KNOWN TO BE NONHAZARDOUS.

FCC Statement:

This equipment has been tested and found to comply with the limits for a Class B digital device, pursuant to Part 15 of the FCC Rules. These limits are designed to provide reasonable protection against harmful interference in a residential installation. This equipment generates, uses and can radiate radio frequency energy and, if not installed and used in accordance with the instructions, may cause harmful interference to radio communications. However, there is no guarantee that interference will not occur in a particular installation. If this equipment does cause harmful interference to radio or television reception, which can be determined by turning the equipment off and on, the user is encouraged to try to correct the interference by one or more of the following measures: Reorient or relocate the receiving antenna; Increase the separation between the equipment and receiver; Connect the equipment into an outlet on a circuit different from that to which the receiver is connected; Consult the dealer or an experienced radio/TV technician for help.

Copyright & Trademarks:

Copyright © SIXNET, All Rights Reserved. EtherTRAK is a registered trademark of SIXNET.

Note: All information in this document is subject to change without notice.

Section 1

General Information

Overview

This manual will help you install and maintain the **EtherTRAK Industrial Ethernet Real-time switches**. These products are extremely easy to install and operate because little or no user configuration is required. Once the Ethernet connections are made and the unit is powered up it will immediately begin to operate.

Operation

Unlike an Ethernet hub that broadcasts all messages out all ports, these switches will intelligently route Ethernet messages only out the appropriate port. The major benefits of this are increased bandwidth and speed, reduction or elimination of message collisions, and deterministic performance when tied with real-time systems.

These switches support both 10BaseT (10 Mbps) and 100BaseTx (100 Mbps) on their RJ45 ports. Each of these ports will independently auto-sense the speed, allowing you to interface to regular or fast Ethernet devices. Some models also have 100BaseFX (100 Mbps) fiber optic port(s).

Refer to Section 6 for more information on operation and features.

Performance Specifications

These general specifications apply to these switches. Refer to Section 7 for complete technical specifications.

Ports (models vary)	10/100BaseT(x) (Shielded RJ45), 100BaseFX (SC or ST connectors)
Required Voltage	10 - 30 VDC (see Section 7 for power consumption for each model)
Ethernet Standards	IEEE 802.3 (10BaseT), 802.3u (100BaseTX), 802.3x (Full Duplex)
Ethernet Protocols	All standard IEEE 802.3 protocols supported
Speed Per Port	RJ45: 10 Mbps (half duplex) or 200 Mbps (full duplex) Fiber: 100 Mbps (half duplex) or 200 Mbps (full duplex)
Ethernet Isolation	1500 Volts RMS (for 1 minute)
Operating Temp.	-40 to 85 °C
Humidity	5 to 95% (non-condensing)
Screw Terminals	14 AWG max. (tighten to 3.48 in.-lbs. max.)

Standards and Safety

The EtherTRAK Industrial Ethernet Switch meets the following standards:

Electrical safety - UL 508, CSA C22/14; EN61010-1 (IEC1010)

EMI emissions - FCC part 15, ICES 003, EN55022; Class B

EMC immunity – EN61326-1 (EN61000-4--2, 3, 4, 5 and 6)

Hazardous locations – UL 1604, CSA C22.2/213 (Class 1, Div. 2), Groups A, B, C, D; Cenelec EN50021 (Zone 2) EEx nA II T4 X (-40°C ≤ T_a ≤ +85°C)

Install the EtherTRAK Industrial Ethernet Switch in accordance with local and national electrical codes.

Lightning Danger: Do not work on equipment during periods of lightning activity.

Do not connect a telephone line into one of the Ethernet RJ45 connectors.



Section 2

LED Indicators

Overview

These switches have communication LEDs for each port and a power LED. Refer to the pictures below for the typical location of these LEDs. The exact location of these LEDs may vary between the different models.

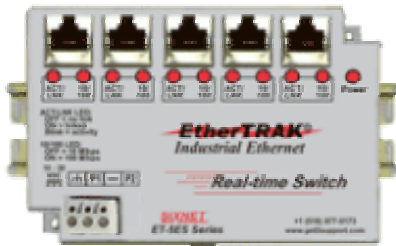

ET-5ES-1
(5 port – all copper)



ET-5ES-2 or -3
(5 port with 1 fiber)

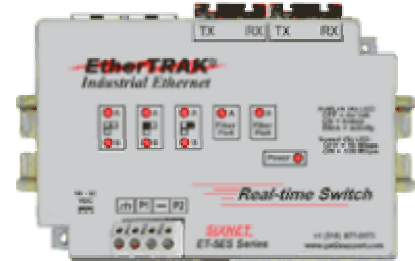

ET-5ES-4 or -5
(5 port with 2 fiber)



ET-GT-9ES-1
(9 port – all copper)

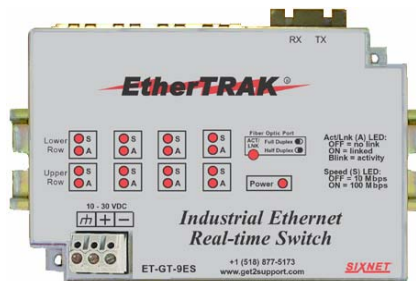

ET-GT-9ES-2 or -3
(9 port with 1 fiber)

Power LED

This LED will be on solid when proper power has been applied to the unit.

ACT / LNK LEDs

The activity (ACT) and link (LNK) indication is combined into one LED (labeled “ACT/LNK” or “A”) on these switches. There is one of these LEDs per port.

OFF – This would indicate that there is not a proper Ethernet connection (Link) between the port and another Ethernet device. Make sure the proper cable type is in use and that it has been plugged securely into the ports at both ends. See section 5 for proper Ethernet cabling.

ON Solid (not flashing) – This would indicate that there is a proper Ethernet connection (Link) between the port and another Ethernet device, but no communications activity is detected.

Flashing – This would indicate that there is a proper Ethernet connection (Link) between the port and another Ethernet device, and that there is communications activity.

10 / 100 LEDs

This LED indicates what speed of communications is detected on the port. There is one of these LEDs per RJ45 port and it is labeled “S”. (The fiber optic port does not have one of these LEDs because its speed is fixed at 100 Mbps.) (Mbps = Megabits per Second)

OFF – A 10 Mbps (10BaseT) connection is detected.

ON – A 100 Mbps (100BaseTx) connection is detected.

Section 3

Installation

Overview

All switches share the same footprint and can be snapped onto a standard DIN rail (EN50022) or screwed directly to a flat panel. Refer to the mechanical drawing below.
Note: The Ethernet connections for the ET-5ES-1 come out the face of the unit. The Ethernet connections for all other models come out the top. Make sure to allow enough room to route your Ethernet cables.

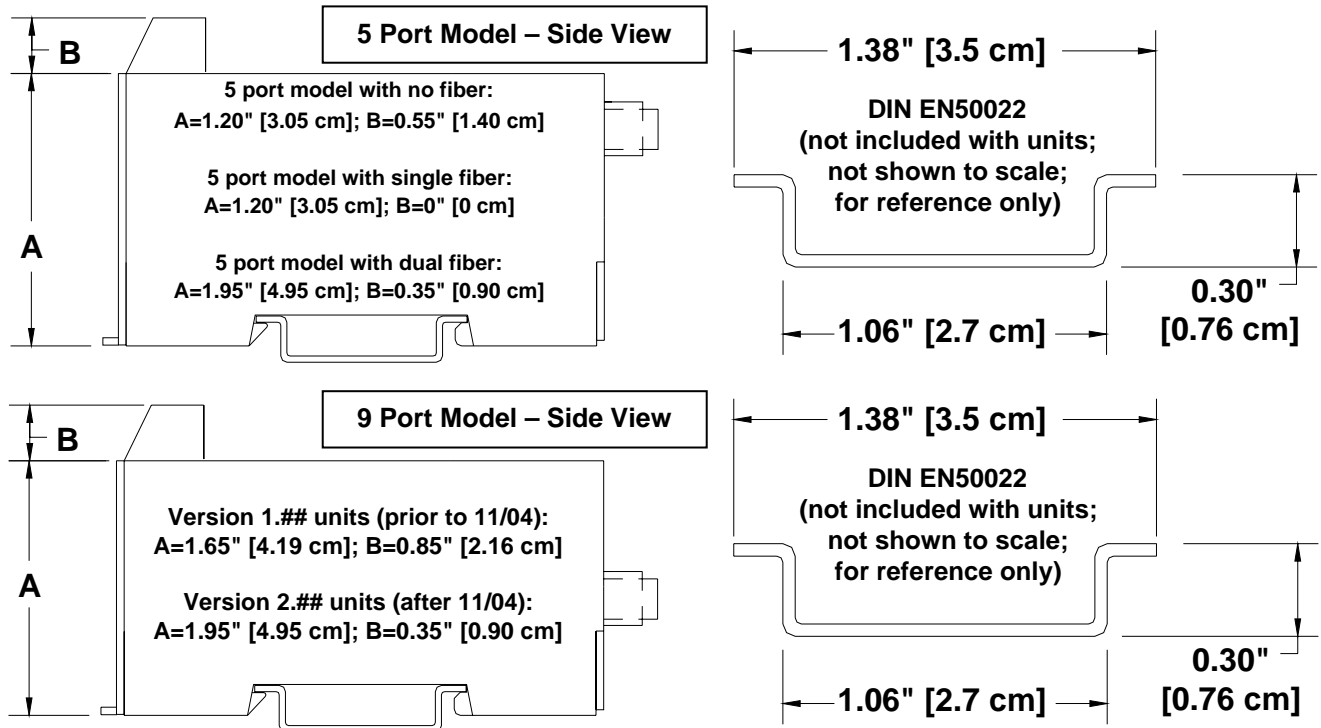
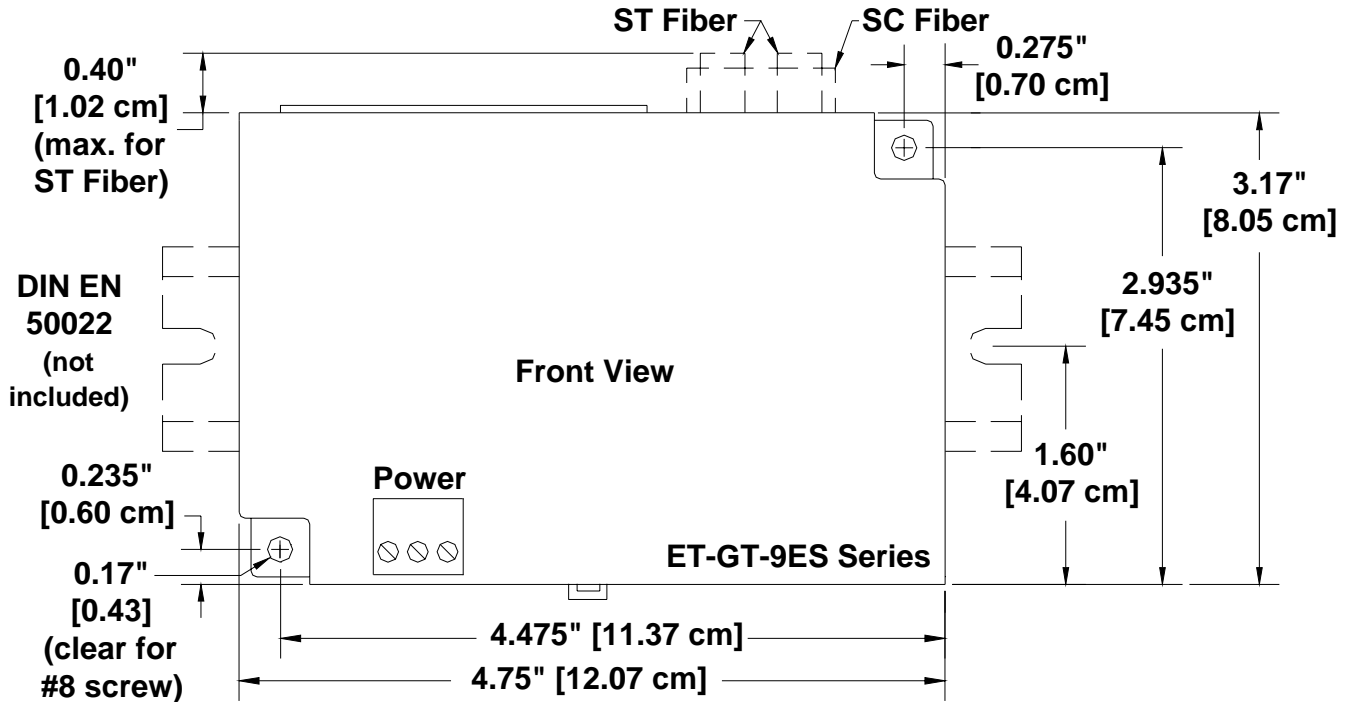

Section 4

Power Wiring

Overview

These switches can be powered from the same DC source that is used to power your I/O devices. 10 to 30 VDC needs to be applied to terminals 2 and 3. Optionally, on the 5ES models a backup power supply may be connected. Refer to the wiring diagram below. Terminal 1 should be tied to panel or chassis ground.

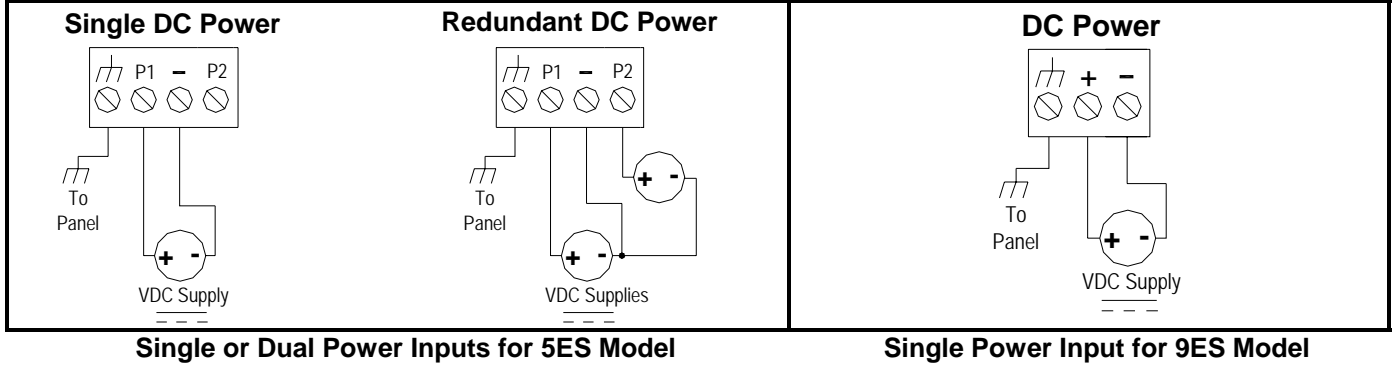

RM-PS-024-01N (optional)

The RM-PS-024-01 can be used to power your switches, instrumentation loops, and other devices. It operates on 85-264 VAC (47-63 Hz) or 120-370 VDC and outputs 24 VDC at up to 1 Amp. Refer to its data sheet for details. Refer to the figure below for the power connections.

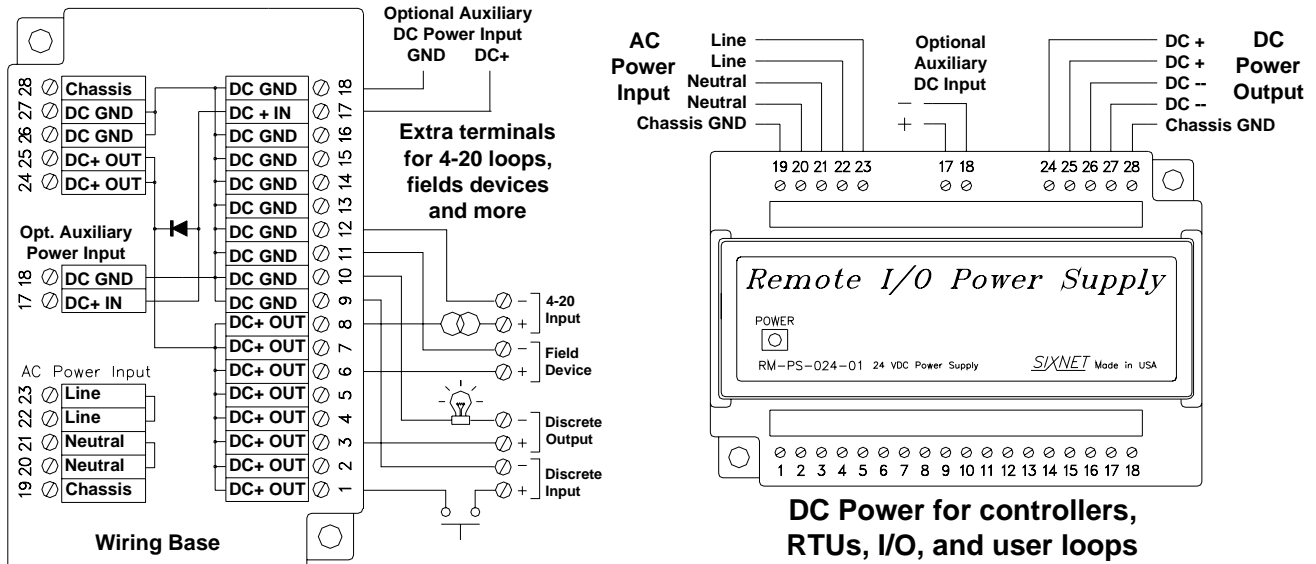

Screw Torque

The screw terminals should be tightened as follows:
Maximum 3.48 in-lbs (0.4 Nm)

Section 5

Ethernet Wiring

Overview

These switches provide connections to Ethernet devices on the factory floor. Typically a port is used to connect to another Ethernet switch or hub that is connected to the main Ethernet backbone. The other Ethernet ports are then connected to Ethernet devices such as PLCs, Ethernet I/O, or industrial computers. Electrical isolation is provided on the Ethernet ports for increased reliability.

Please follow normal Ethernet wiring practices when installing these switches.

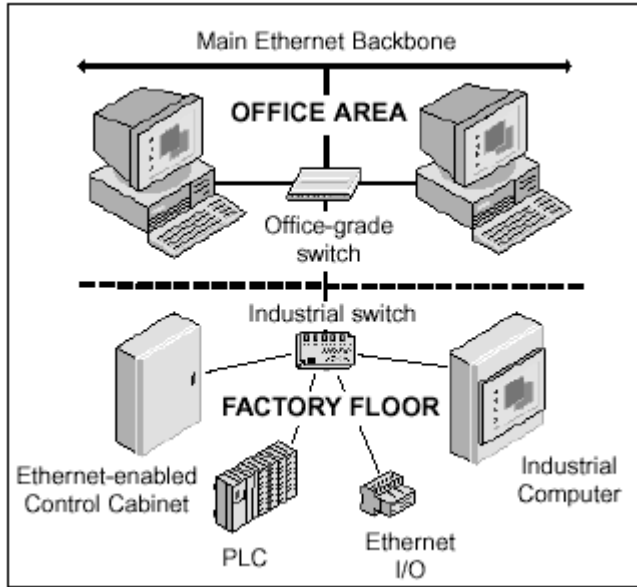

Typical EtherTRAK Industrial Ethernet Switch Installation

Refer to the SIXNET On-line Catalog for More Usage Ideas

RJ45 Wiring Guidelines

Use data-quality (not voice-quality) twisted pair cable rated category 5 (or better) with standard RJ45 connectors. For best performance use shielded cable. Please note that these cables are available as straight-thru or cross-over configurations. Either type can be used because these switches support auto-mdi/mdix-crossover. For reference, the pin-outs of the two cable types are listed below.

Ethernet Cable Pin-outs

Straight-thru Cable Wiring		Cross-over Cable Wiring	
Pin 1	Pin 1	Pin 1	Pin 3
Pin 2	Pin 2	Pin 2	Pin 6
Pin 3	Pin 3	Pin 3	Pin 1
Pin 6	Pin 6	Pin 6	Pin 2

Ethernet Connector Pin Positions

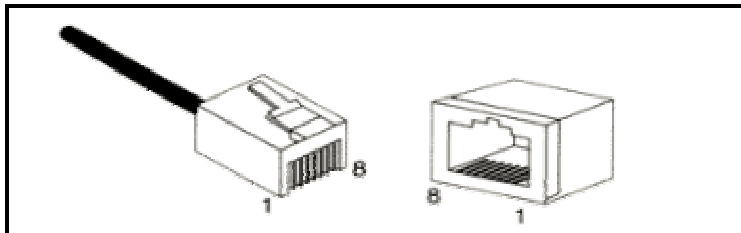

Ethernet Connector Pin-outs

Pin #	MDI-X Port	MDI Port (typical for uplink)	Auto-MDI/MDI-X	Ethernet Device Port
1	TX+	RX+	TX/RX+	RX+
2	TX-	RX-	TX/RX-	RX-
3	RX+	TX+	RX/TX+	TX+
6	RX-	TX-	RX/TX-	TX-

Cable Distance

The maximum cable length for 10/100BaseT(x) is typically 100 meters (328 ft.).

From	To	Maximum Distance
Switch	Switch or Hub	100 meters (328 feet)
Switch or Hub	PLC, Ethernet I/O, PC, etc.	100 meters (328 feet)

Note: Hubs and switches are different devices. Hubs simply broadcast all messages out all ports. switches intelligently route messages only out the appropriate port

Ethernet Fiber Wiring Guidelines

These switches may have one or two pair of fiber ports of the type multimode or singlemode. Multimode ports support a maximum segment length of 2 km. Singlemode ports support a maximum segment length of 15 km, 40 km (long haul models) or even more (contact SIXNET.)

Each fiber optic port on the switch is comprised of a pair of SC or ST connectors, which are labeled with “RX” and “TX” on the switch. When making your fiber optic connections, make sure that the transmit (TX) port of the switch connects to the receive (RX) port of the other device, and the receive (RX) port of the switch connects to the transmit (TX) port of the other device.

The ACT/LNK LED will be ON solid when you have made a proper connection.

Full or Half Duplex Operation

The RJ45 ports will auto-sense for Full or Half duplex operation. No user configuration is necessary. Each fiber optic port has a movable slide-switch or jumper that allows you to select the mode. The metal cover needs to be removed to access the movable jumper. See diagram below.

Note: You must cycle power to the switch after changing the slide-switch or jumper position.

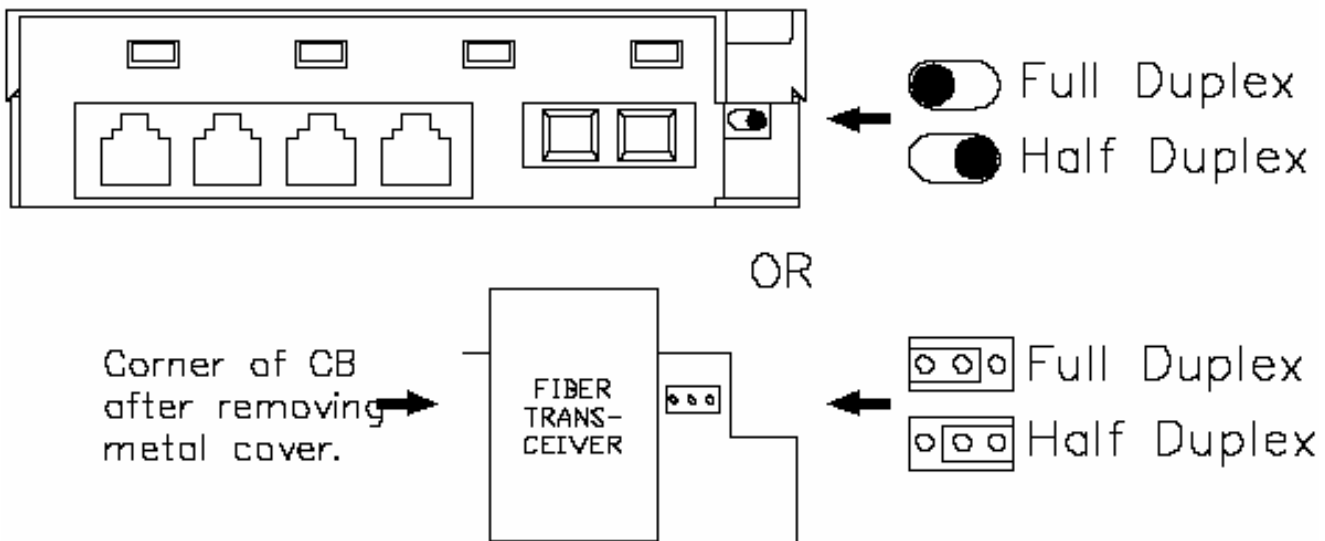

Switching Features

Here's a brief explanation of some of the features found in these switches documented by this manual.

10BaseT and 100BaseTx Auto-detection

Standard Ethernet (10BaseT) has a maximum speed of 10 Mbps in half duplex mode. Fast Ethernet (100BaseTx) has a maximum speed of 200 Mbps in full duplex mode. The RJ45 ports on these switches automatically select the appropriate speed.

100BaseFX (multimode and singlemode) fiber optic port

The fiber optic port found on some models is classified as 100BaseFX and supports 100 Mbps operation only. Both multimode and singlemode models are available. Multimode allows for multiple wavelengths over a cable with a core diameter of typically 50 or 62.5 microns. The maximum distance for multimode is 2 km. Singlemode uses a single wavelength and cable core diameter of around 10 microns which allows for a maximum distance of 15 km, 40 km or more (contact SIXNET for longer distances).

3.2 Gbps combined bandwidth

With full duplex and 100BaseTX or 100BaseFX communications, each port can provide a full 200 Mbps of data throughput.

1K MAC addresses with automatic learning, aging and migration

Each Ethernet device inserts its unique "MAC" address into each message it sends out. The port on the switch used for a given MAC address is automatically learned when a frame is received from that address. Once an address is learned, the switch will route messages to only the appropriate port, instead of broadcasting messages out all ports like a hub. A time stamp is also placed in memory when a new address is learned. This time stamp is used with the aging feature, which will remove unused MAC addresses from the table after 300 seconds. If a device moves, the associated port on the switch will be changed (migrated) as needed. Up to 1,024 MAC addresses can be stored and monitored at any time.

Auto-crossover (auto-mdi/mdix)

The RJ45 ports will automatically detect the cable type (straight-thru vs. cross-wired) and re-configure themselves accordingly.

Auto-polarity

The RJ45 ports will automatically correct for reversed polarity on the TD and RD pair.

Auto-sensing or auto-negotiating speed

The RJ45 ports of these switches will auto-negotiate with the connected device to determine the optimal speed (10 Mbps vs. 100 Mbps).

Automatic power saving

If there is no cable on a port, most of the circuitry for that port is disabled to save power.

Back pressure for half-duplex

The EtherTRAK Industrial Ethernet Switch will apply "back pressure" when necessary with half-duplex operation. This "back pressure" will reduce congestion on busy networks.

Buffering

SRAM is used for buffering the messages. The 5ES switches have ½ Mbits (64 Kbytes) while the 9ES switches have 1 Mbits (128 Kbytes). The buffer size is automatically allocated for each port as necessary.

Unmanaged operation

These switches require no supervisory processor to operate properly.

Flow control

These switches automatically support flow control frames on both the transmit and receive sides. Back-pressure flow control for half-duplex ports and pause-frame flow control for full-duplex ports.

Forwarding

These switches support store and forward mode. They will forward messages with known addresses out only the appropriate port. Messages with unknown addresses, broadcast messages, and multicast messages will get forwarded out all ports except the source port.

Full / Half duplex operation

The RJ45 ports of these switches support both full and half duplex flow control. The fiber optic port(s) has a settable jumper or switch, which allows you to select the desired operation.

Illegal frames

Illegal frames as defined by IEEE 802.3 will be dropped. This includes short frames, long frames, CRC error frames and alignment error frames.

IEEE 802.3 compliant

The EtherTRAK Industrial Ethernet Switch strictly abides to the IEEE 802.3 standard for 10BaseT, 100BaseTX, and 100BaseFX Ethernet communications.

Latency

The typical latency of a message at 100 Mbps is 5 microseconds or faster. The latency is the time it takes a message to be routed internal to a switch from one port to another.

Non-blocking

This means that the switches offer the best in performance and are capability of full-wire speed transmissions.

Plug and play

This means that most functions or features of these switches are automatic and that there are minimal or no optional parameters that need to be set. Just plug in your Ethernet cables, apply power, and the unit will immediately begin to operate.

Protocol independent

These switches will work with all popular Ethernet protocols and networks such as TCP/IP, the Internet (IP), UDP, NetBEUI, and many more. It is compatible with all protocols that run over standard Ethernet (IEEE 802.3). In fact, it will support packets of different protocols simultaneously.

Section 7

Technical Specifications

Technical Specifications

Here are the technical specifications for these switches covered by this manual.

Copper Ports: (10/100BaseTx)	
10/100BaseT(x) ports	Shielded RJ45
Protocols supported	All standard IEEE 802.3
Ethernet compliancy	IEEE 802.3, 802.3u, 802.3x
Auto-crossover	Yes , Auto-mdi/mdix-crossover
Auto-negotiating	10BaseT or 100BaseTX
Auto-polarity	Yes
Flow control	Half or full duplex
Ethernet isolation	1500 VRMS 1 minute
Plug and play	Yes
Cable requirements	Twisted pair (Cat. 5 or better) (shielded recommended)
Max. cable distance	100 meters
Multimode Fiber Port: (100BaseFX)	
Fiber port mode	Multimode
Fiber port connector	Duplex SC or ST
Optimal fiber cable	50/125, 62.5/125 μm
Center wavelength	1300 nm
TX output power	Contact SIXNET for optical details.
RX input sensitivity	
Maximum distance	2 km
Half and full duplex	Switch or jumper selectable
Ethernet compliance	100BaseFX
Eye safety	IEC 60825-1, Class 1; FDA 21 CFR 1040.10 and 1040.11
Singlemode Fiber Port: (100BaseFX)	
Fiber port mode	Singlemode
Fiber port connector	Duplex SC or ST
Optimal fiber cable	9/125, 10/125 μm
Center wavelength	1300 nm
TX output power	Contact SIXNET for optical details.
RX input sensitivity	
Maximum distance	15 km, 40 km (long haul models) or more (contact SIXNET)
Half and full duplex	Switch or jumper selectable
Ethernet compliance	100BaseFX
Eye safety	IEC 60825-1, Class 1; FDA 21 CFR 1040.10 and 1040.11

General:	
Operation	Unmanaged, Store and forward, non-blocking
Compliance	IEEE 802.3 (10BaseT), 802.3u (100BaseTX), 802.3x (Flow Control)
Latency (typical)	5 usec (time to route a message from one port to another internal to switch)
Memory bandwidth	3.2 Gbps
MAC addresses	1K (1024)
Address learning	Automatic
Address aging	Remove old address after 300s
Address migration	Automatic
Back pressure	Automatic for half-duplex
Buffer memory	64KB (5ES models) or 128KB (9ES models)
Buffers per port & buffer size	Automatic and dynamic
Illegal frames	Dropped per 802.3
Flow control	Yes, for half and full duplex
Environmental:	
Required supply voltage	10 – 30 VDC
Power consumption (typical); (Max. 8 Watts) (Note: Power consumption varies on speed and amount of activity of each port.)	5ES-1: 4.0 Watts 5ES-2/3: 5.0 Watts 5ES-4/5: 6.0 Watts 9ES-1: 6.0 Watts 9ES-2/3: 7.0 Watts
Power saving	Automatic
Max. screw terminal torque and wire gauge	3.48 in-lbs (0.4 Nm), 14 AWG
Operating temp. range	-40 to 85 °C
Storage temp. range	-40 to 85 °C
Humidity	5 to 95 % (non-condensing)
Flammability	UL 94V-0 materials
Electrical safety	UL508, CSA C22/14; EN61010-1 (IEC1010), CE
EMI emissions	FCC part 15, ICES 003, EN55022; Class B; CE
EMC immunity and surge withstand	EN61326-1 (EN61000-4-2, 3, 4, 5, 6), IEEE-472 (ANSI C37.90), CE
Vibration	IEC68-2-6
Hazardous locations	UL1604, CSA C22.2/213 (Class 1, Div. 2), Cenelec EN50021 (Zone 2)
Marine and offshore	DNV tested
Dimensions	See mechanical diagrams
Mounting	DIN rail or panel direct

Section 8

Service Information

Service Information

We sincerely hope that you never experience a problem with any **SIXNET** product. If you do need service, call **SIXNET** at (518) 877-5173 and ask for Applications Engineering. A trained specialist will help you to quickly determine the source of the problem. Many problems are easily resolved with a single phone call. If it is necessary to return a unit to us, an RMA (Return Material Authorization) number will be given to you.

SIXNET tracks the flow of returned material with our RMA system to ensure speedy service. You must include this RMA number on the outside of the box so that your return can be processed immediately.

The applications engineer you are speaking with will fill out an RMA request for you. If the unit has a serial number, we will not need detailed financial information. Otherwise, be sure to have your original purchase order number and date purchased available.

We suggest that you give us a repair purchase order number in case the repair is not covered under our warranty. You will not be billed if the repair is covered under warranty.

Please supply us with as many details about the problem as you can. The information you supply will be written on the RMA form and supplied to the repair department before your unit arrives. This helps us to provide you with the best service, in the fastest manner. Normally, repairs are completed in two days. Sometimes difficult problems take a little longer to solve.

If you need a quicker turnaround, ship the unit to us by air freight. We give priority service to equipment that arrives by overnight delivery. Many repairs received by mid-morning (typical overnight delivery) can be finished the same day and returned immediately.

We apologize for any inconvenience that the need for repair may cause you. We hope that our rapid service meets your needs. If you have any suggestions to help us improve our service, please give us a call. We appreciate your ideas and will respond to them.

For Your Convenience:

Please fill in the following and keep this manual with your **SIXNET** system for future reference:

P.O. #: _____ Date Purchased: _____

Purchased From: _____

Product Support

To obtain support for **SIXNET** products:

On-line support: <http://www.get2support.com>

Order on-line: <http://www.sixnetstore.com>

Latest product info: <http://www.sixnetio.com>

Phone: +1 (518) 877-5173

Fax: +1 (518) 877-8346

E-mail: <mailto:support@sixnetio.com>

Mailing address: **SIXNET**, 331 Ushers Road, P.O. Box 767, Clifton Park, NY 12065